

TOSHIBA

FILE NO. 050-200422

CIRCUIT DIAGRAMS

COLOR TELEVISION

26HF84A

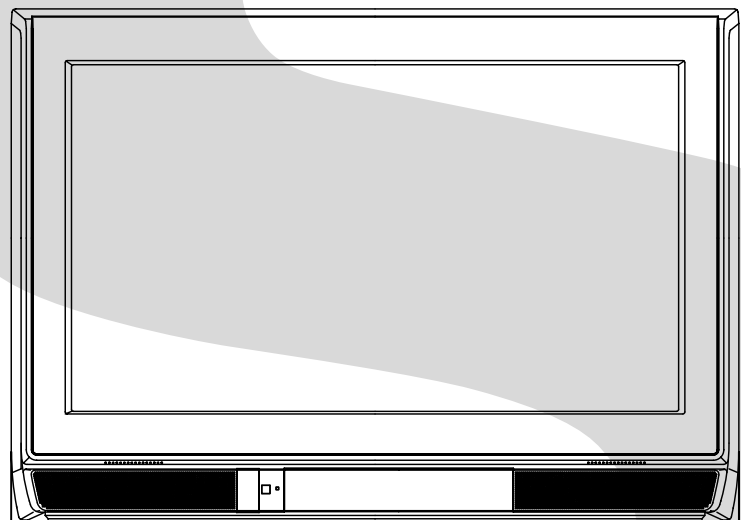

TV BLOCK DIAGRAM

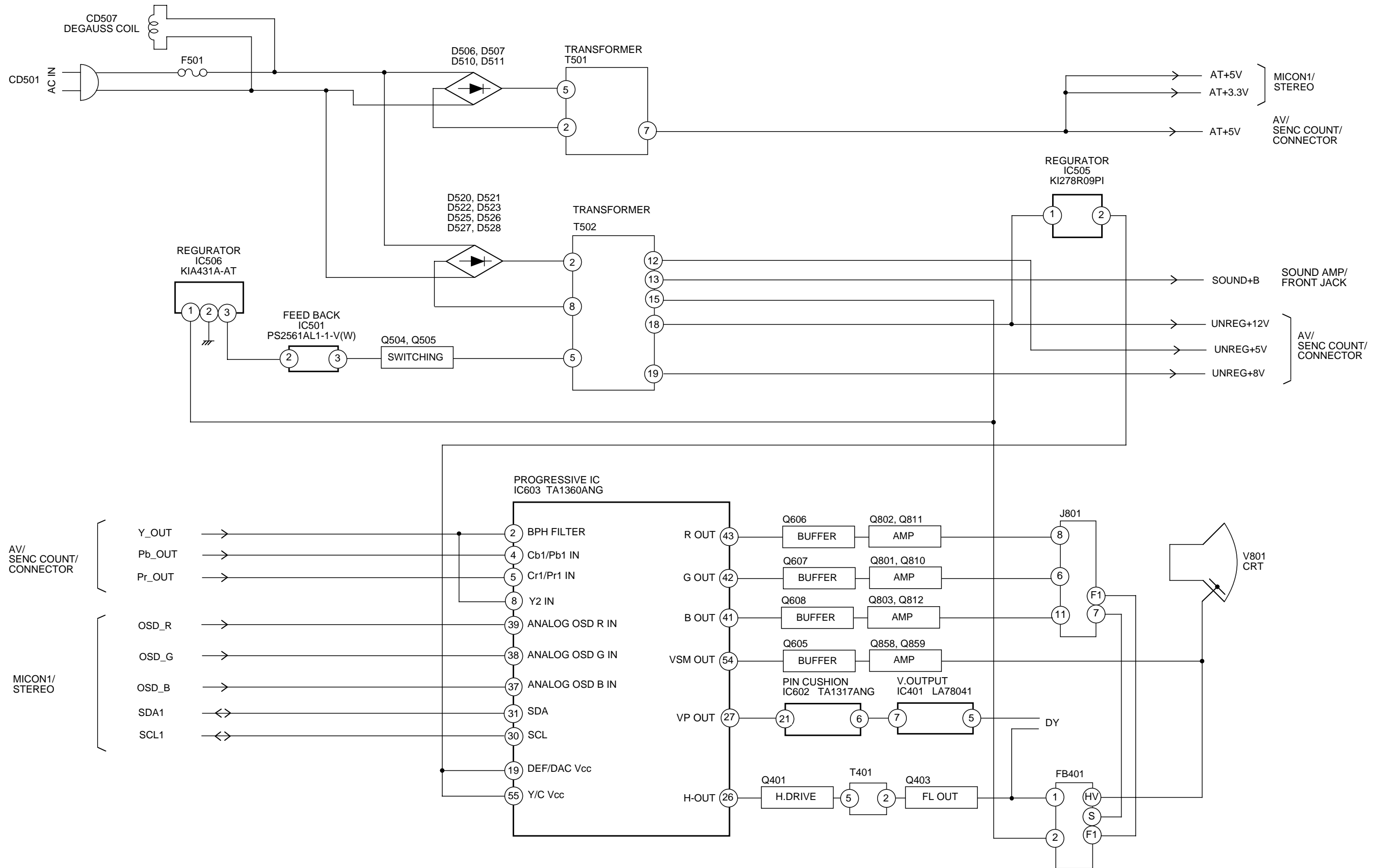

SOUND AMP/FRONT JACK BLOCK DIAGRAM

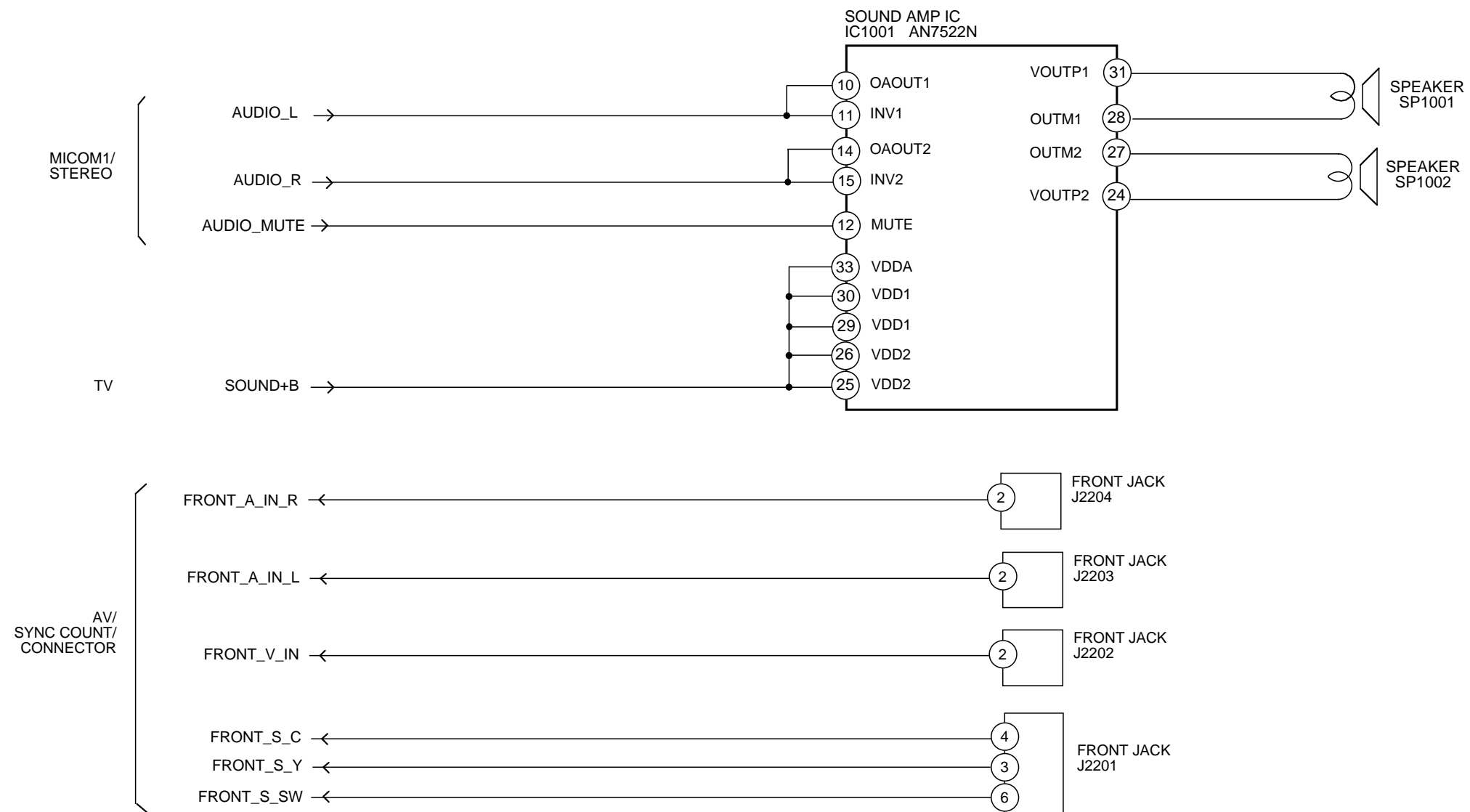

MICON1/STEREO BLOCK DIAGRAM

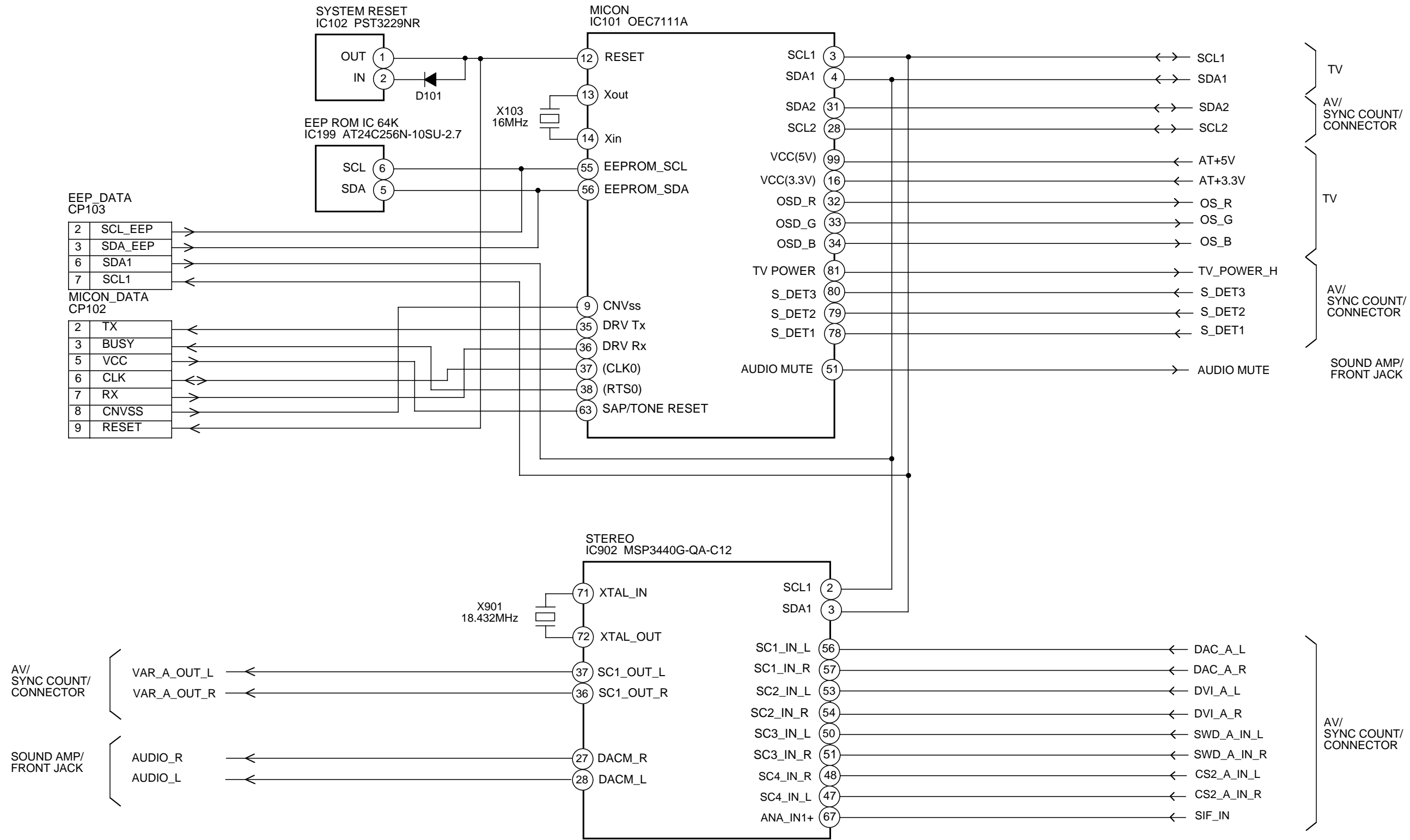

AV/SYNC COUNT BLOCK DIAGM

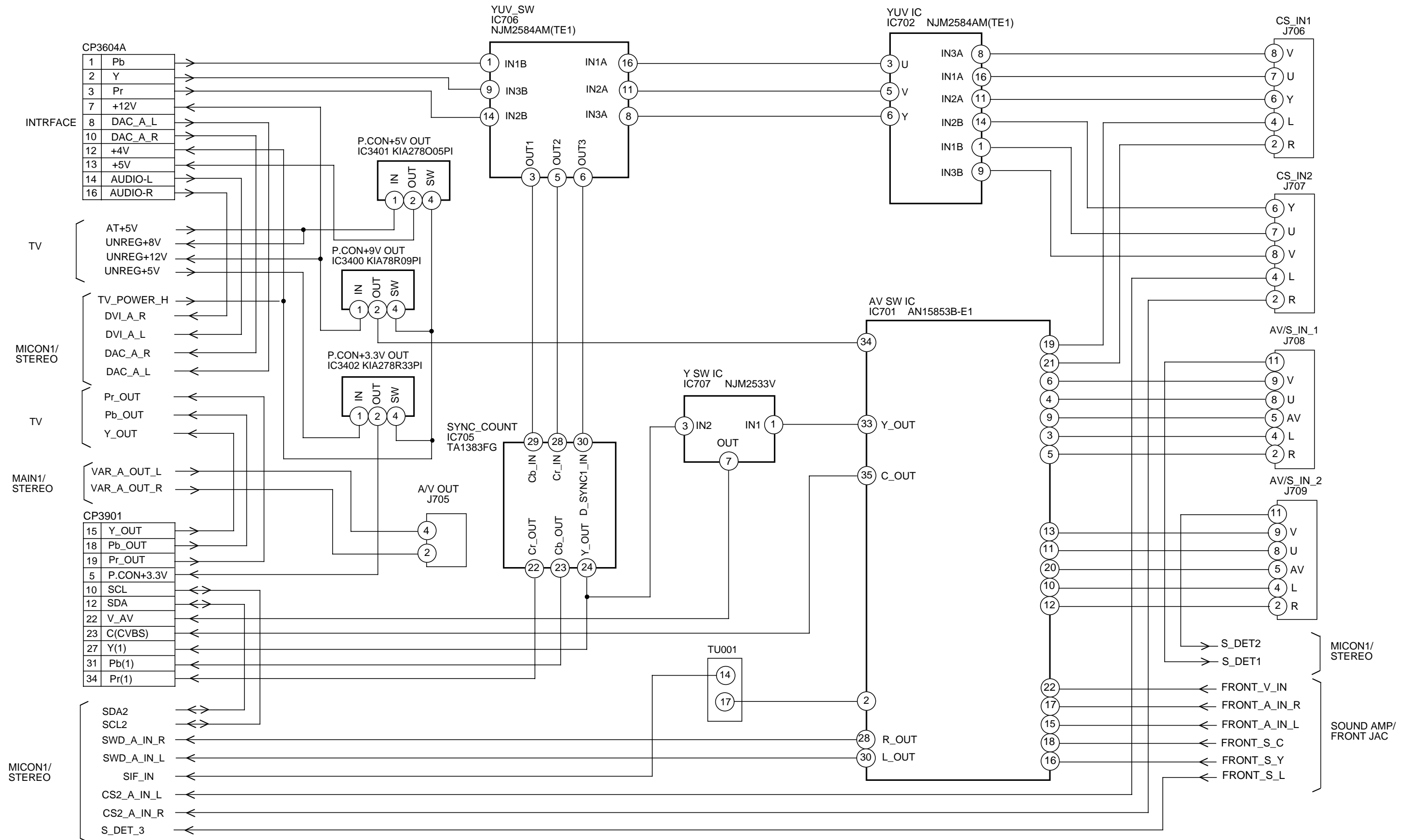

INTERFACE BLOCK DIAGRAM

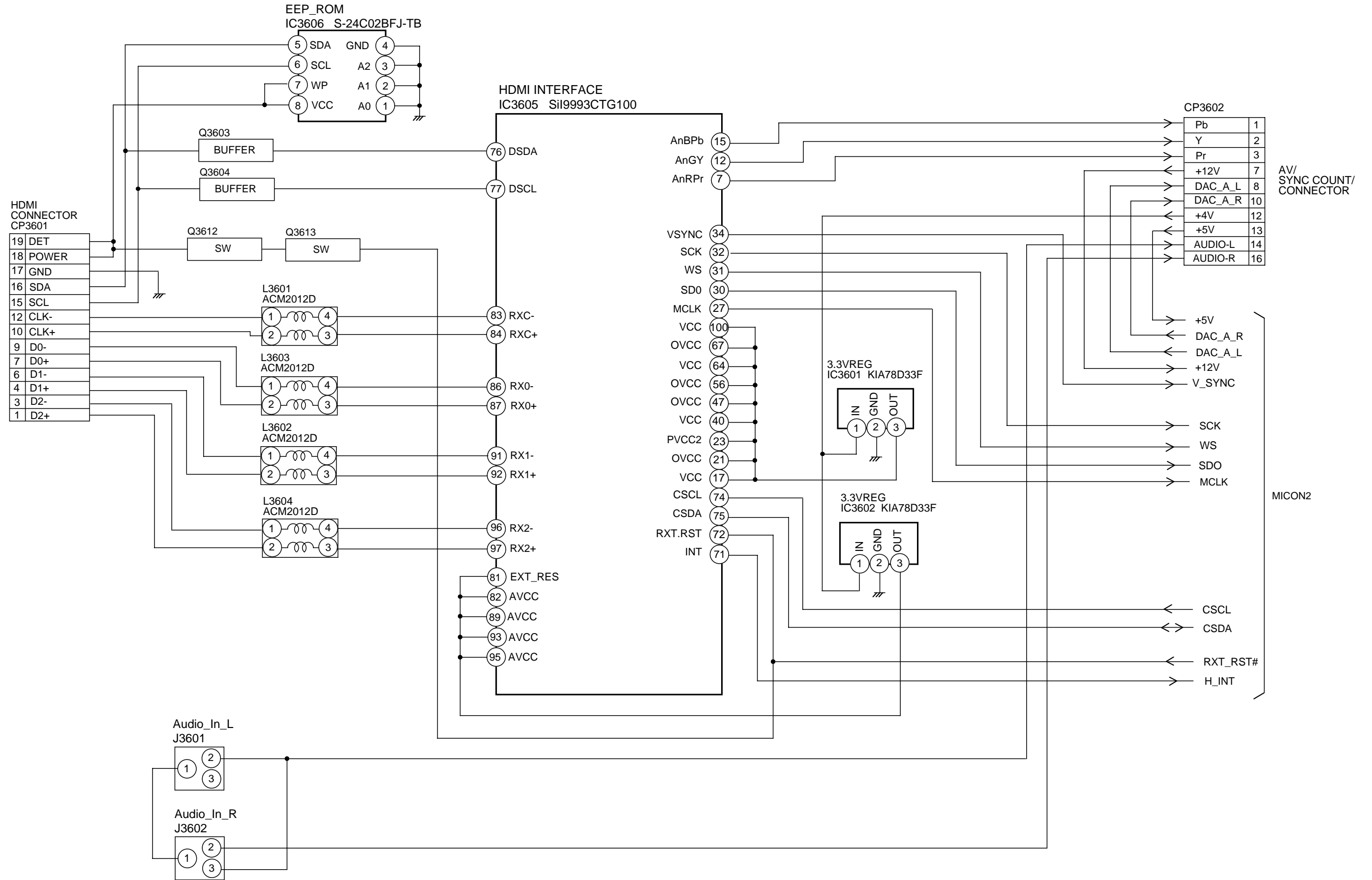

MICON2 BLOCK DIAGRAM

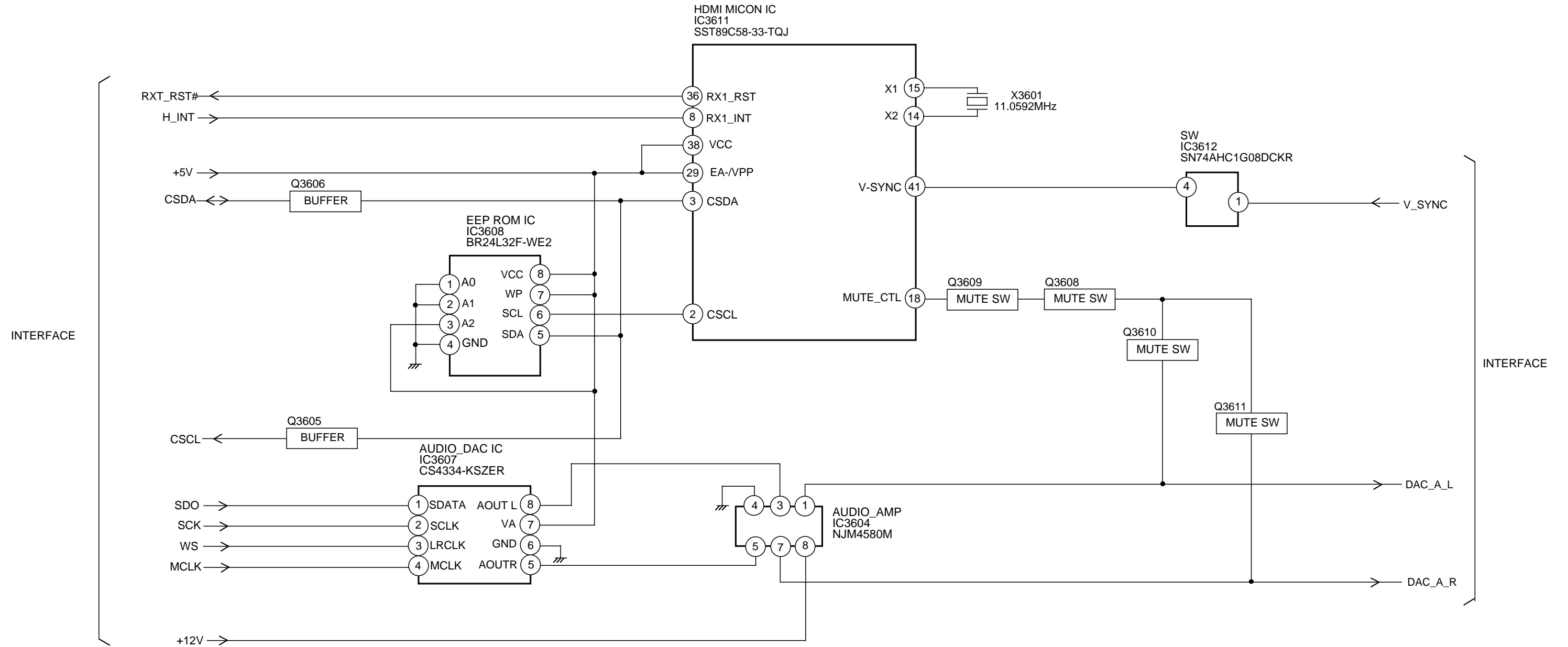

SCALER BLOCK DIAGRAM

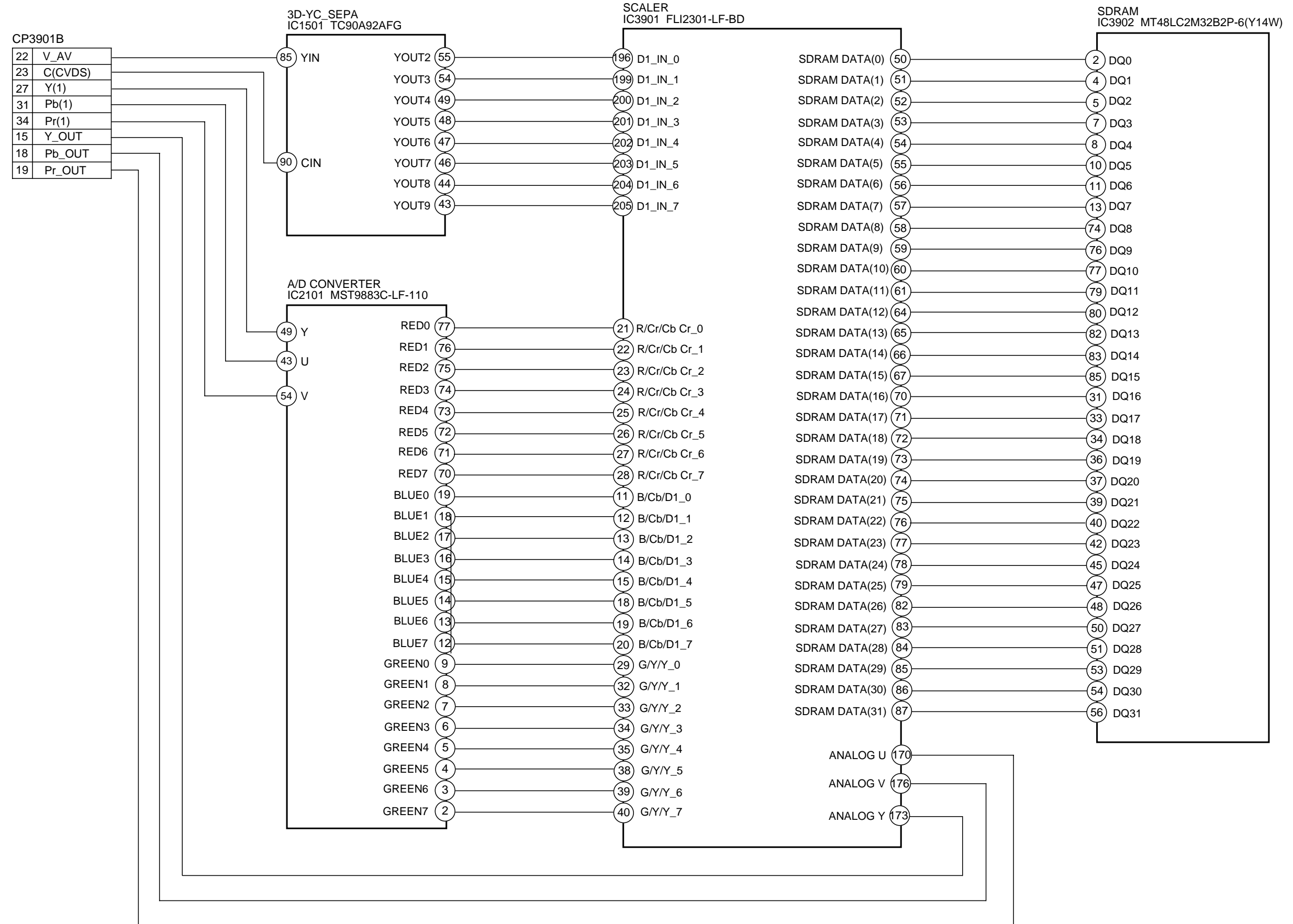

CHROMA/PROGRESSIVE/PIN CUSHION SCHEMATIC DIAGRAM (MAIN PCB)

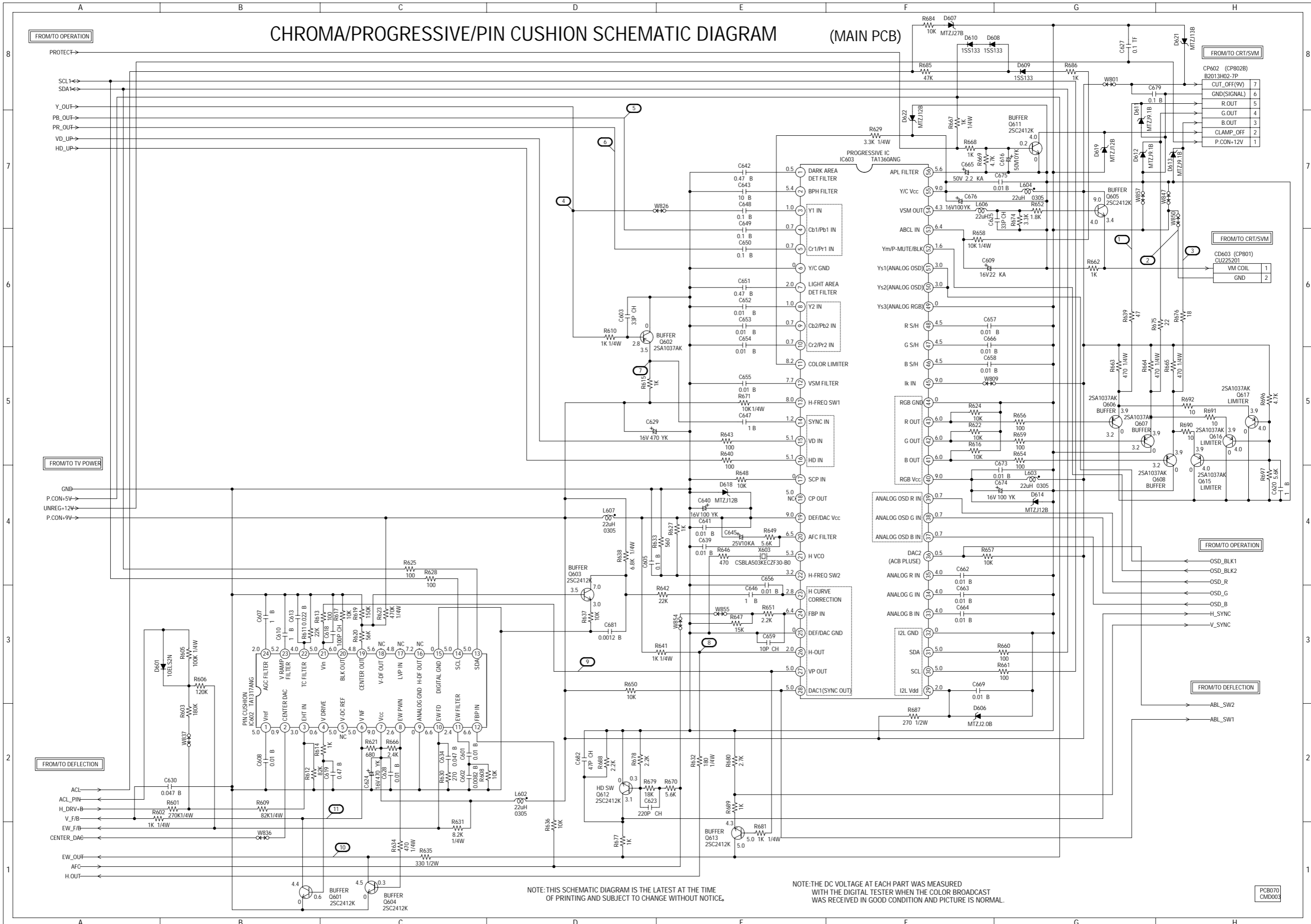

NOTE: THIS SCHEMATIC DIAGRAM IS THE LATEST AT THE TIME OF PRINTING AND SUBJECT TO CHANGE WITHOUT NOTICE.

NOTE: THE DC VOLTAGE AT EACH PART WAS MEASURED WITH THE DIGITAL TESTER WHEN THE COLOR BROADCAST WAS RECEIVED IN GOOD CONDITION AND PICTURE IS NORMAL.

PCB070
CMD003

DEFLECTION SCHEMATIC DIAGRAM (MAIN PCB)

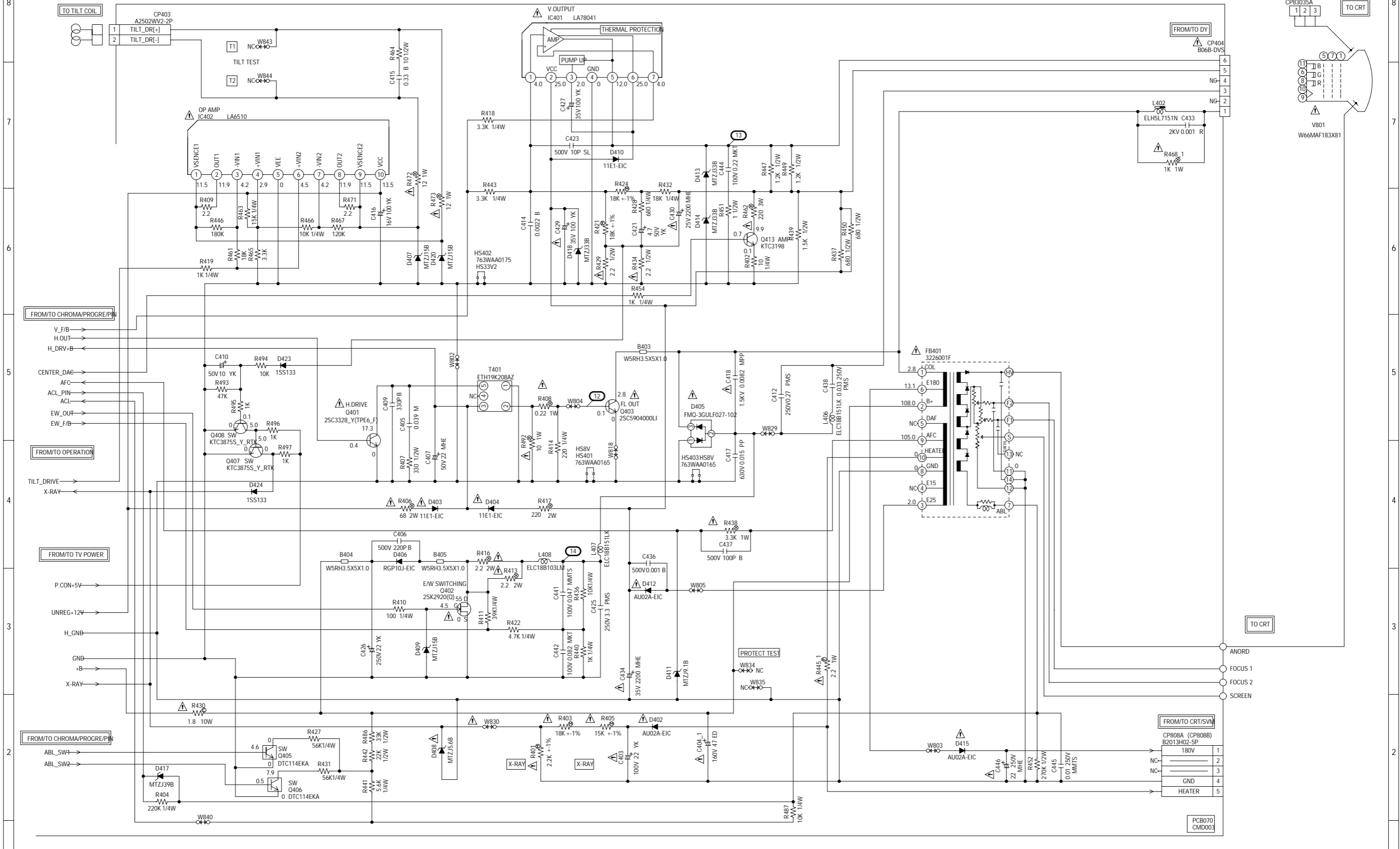

TV POWER SCHEMATIC DIAGRAM (MAIN PCB)

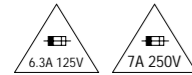
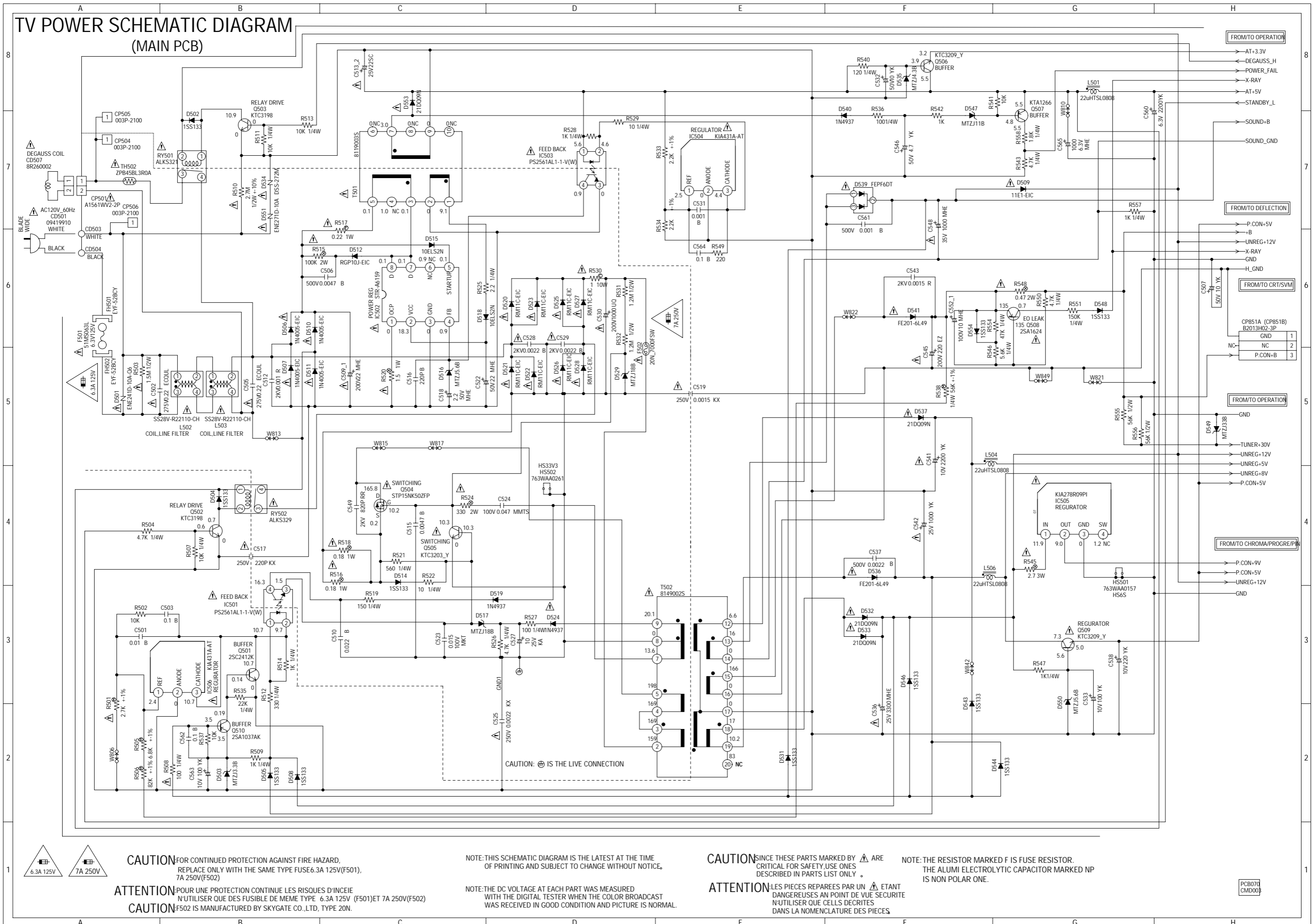

CAUTION FOR CONTINUED PROTECTION AGAINST FIRE HAZARD, REPLACE ONLY WITH THE SAME TYPE FUSE 6.3A 125V (F501), 7A 250V (F502)

ATTENTION POUR UNE PROTECTION CONTINUE LES RISQUES D'INCENDIE N'UTILISER QUE DES FUSIBLES DE MEME TYPE 6.3A 125V (F501) ET 7A 250V (F502)
CAUTION F502 IS MANUFACTURED BY SKYGATE CO., LTD, TYPE 20N.

NOTE: THIS SCHEMATIC DIAGRAM IS THE LATEST AT THE TIME OF PRINTING AND SUBJECT TO CHANGE WITHOUT NOTICE.

NOTE: THE DC VOLTAGE AT EACH PART WAS MEASURED WITH THE DIGITAL TESTER WHEN THE COLOR BROADCAST WAS RECEIVED IN GOOD CONDITION AND PICTURE IS NORMAL.

CAUTION SINCE THESE PARTS MARKED BY ARE CRITICAL FOR SAFETY, USE ONES DESCRIBED IN PARTS LIST ONLY.

ATTENTION LES PIÈCES REPARÉES PAR UN ÉTANT DANGEREUSES AU POINT DE VUE SÉCURITÉ N'UTILISER QUE CELLES DÉCRITES DANS LA NOMÉNCLATURE DES PIÈCES.

NOTE: THE RESISTOR MARKED F IS FUSE RESISTOR. THE ALUMI ELECTROLYTIC CAPACITOR MARKED NP IS NON POLAR ONE.

PCB070 CMM003

OPERATION SCHEMATIC DIAGRAM (MAIN PCB)

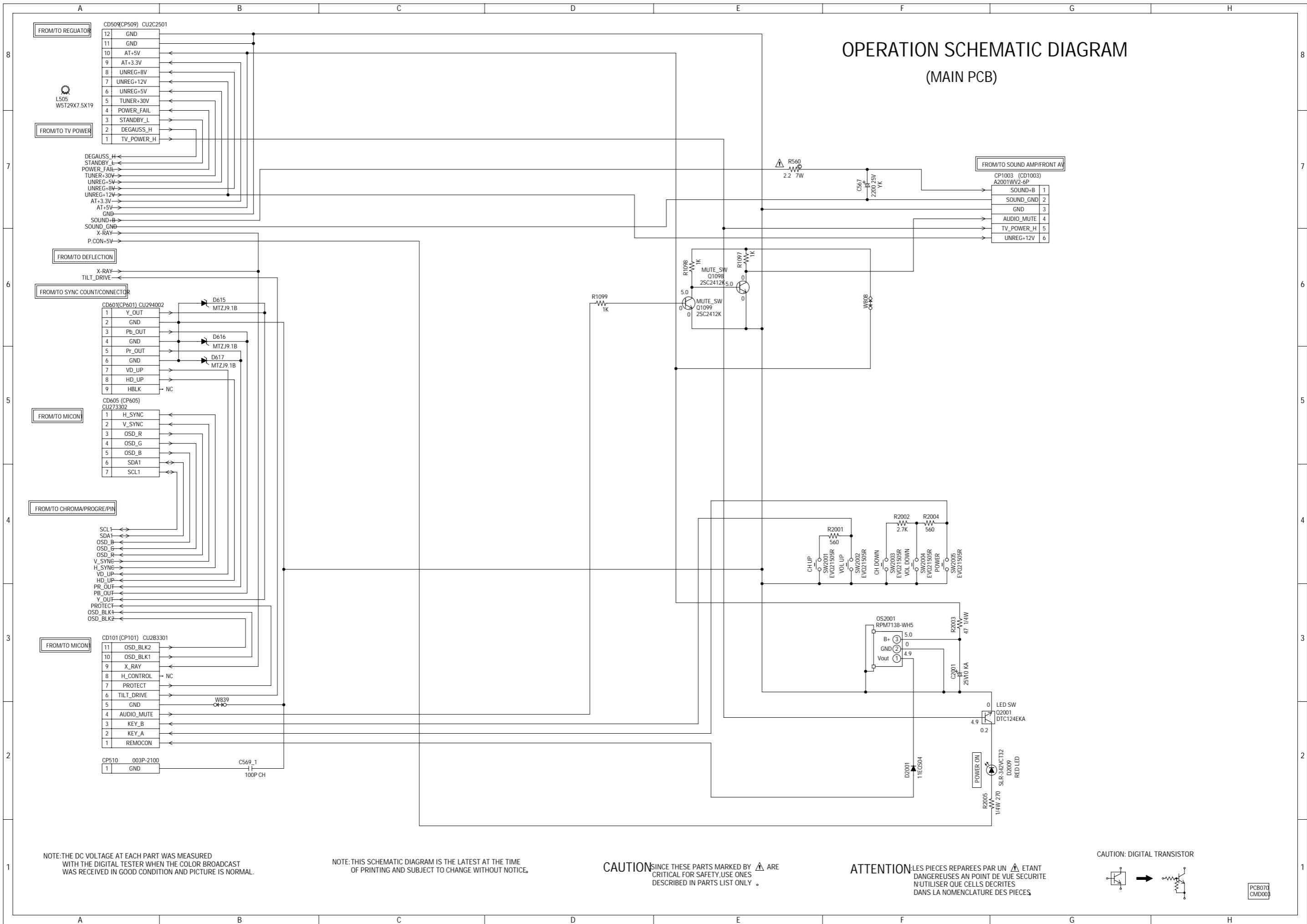

NOTE: THE DC VOLTAGE AT EACH PART WAS MEASURED WITH THE DIGITAL TESTER WHEN THE COLOR BROADCAST WAS RECEIVED IN GOOD CONDITION AND PICTURE IS NORMAL.

NOTE: THIS SCHEMATIC DIAGRAM IS THE LATEST AT THE TIME OF PRINTING AND SUBJECT TO CHANGE WITHOUT NOTICE.

CAUTION SINCE THESE PARTS MARKED BY ARE CRITICAL FOR SAFETY, USE ONES DESCRIBED IN PARTS LIST ONLY.

ATTENTION LES PIÈCES RÉPARÉES PAR UN ÉTANT DANGEREUSES AN POINT DE VUE SECURITE N'UTILISER QUE CELLES DECRITES DANS LA NOMENCLATURE DES PIÈCES.

CAUTION: DIGITAL TRANSISTOR

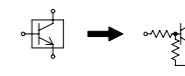

PCB070
CMD003

SOUND AMP/FRONT AV SCHEMATIC DIAGRAM

(FRONT JACK PCB)

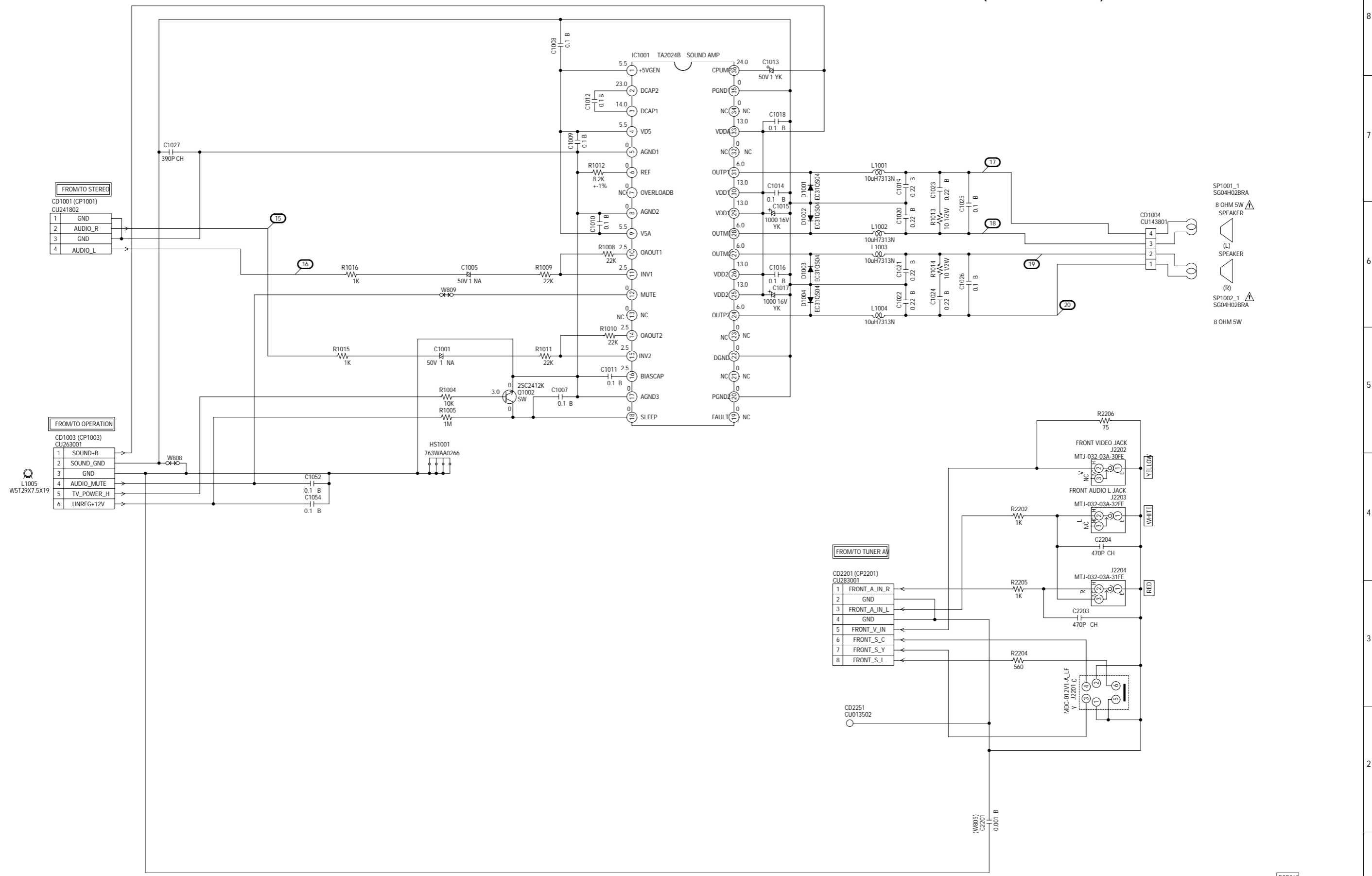

- SP1001_1
SG04H02BRA
8 OHM 5W
SPEAKER
- (L)
SPEAKER
- (R)
SP1002_1
SG04H02BRA
8 OHM 5W

CAUTION SINCE THESE PARTS MARKED BY ARE CRITICAL FOR SAFETY, USE ONES DESCRIBED IN PARTS LIST ONLY.

ATTENTION LES PIÈCES RÉPARÉES PAR UN ÉTANT DANGEREUSES AU POINT DE VUE SÉCURITÉ N'UTILISER QUE CELLES DÉCRITES DANS LA NOMENCLATURE DES PIÈCES.

NOTE: THIS SCHEMATIC DIAGRAM IS THE LATEST AT THE TIME OF PRINTING AND SUBJECT TO CHANGE WITHOUT NOTICE.

NOTE: THE DC VOLTAGE AT EACH PART WAS MEASURED WITH THE DIGITAL TESTER WHEN THE COLOR BROADCAST WAS RECEIVED IN GOOD CONDITION AND PICTURE IS NORMAL.

PCB260
CED008

MICON1 SCHEMATIC DIAGRAM (AV PCB)

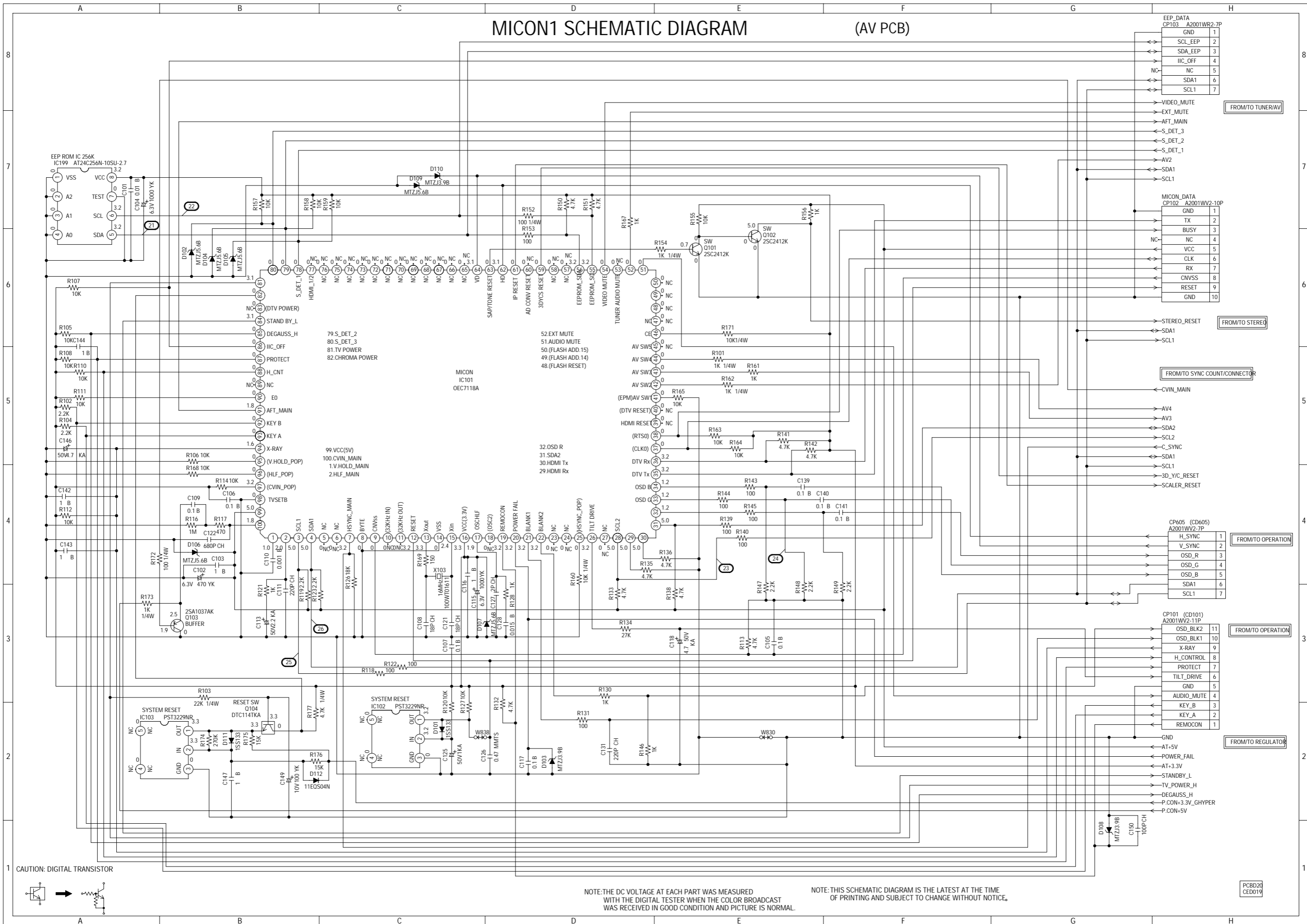

EEP_DATA	
CP103	A2001WR2-7P
1	GND
2	SCL_EEP
3	SDA_EEP
4	IIC_OFF
5	NC
6	SDA1
7	SCL1

MICON_DATA	
CP102	A2001WV2-10P
1	GND
2	TX
3	BUSY
4	NC
5	VCC
6	CLK
7	RX
8	CNVSS
9	RESET
10	GND

CP605 (CD605)	
A2001WV2-7P	
1	H_SYNC
2	V_SYNC
3	OSD_R
4	OSD_G
5	OSD_B
6	SDA1
7	SCL1

CP101 (CD101)	
A2001WV2-11P	
11	OSD_BLK2
10	OSD_BLK1
9	X-RAY
8	H_CONTROL
7	PROTECT
6	TILT_DRIVE
5	GND
4	AUDIO_MUTE
3	KEY_B
2	KEY_A
1	REMOCON

CAUTION: DIGITAL TRANSISTOR

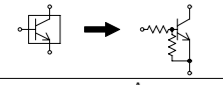

NOTE: THE DC VOLTAGE AT EACH PART WAS MEASURED WITH THE DIGITAL TESTER WHEN THE COLOR BROADCAST WAS RECEIVED IN GOOD CONDITION AND PICTURE IS NORMAL.

NOTE: THIS SCHEMATIC DIAGRAM IS THE LATEST AT THE TIME OF PRINTING AND SUBJECT TO CHANGE WITHOUT NOTICE.

PCBD20 CED019

STEREO SCHEMATIC DIAGRAM

(AV PCB)

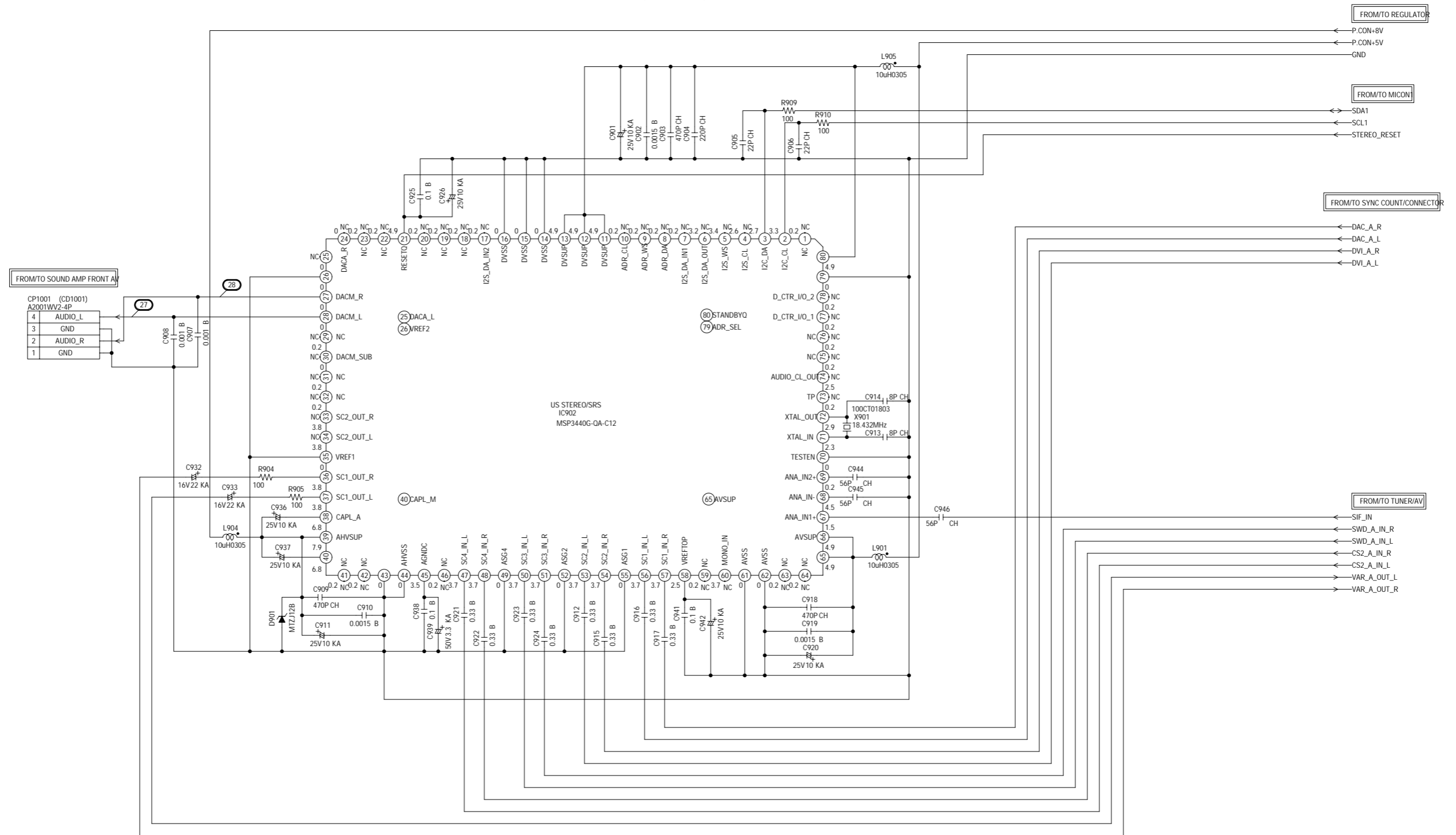

NOTE: THIS SCHEMATIC DIAGRAM IS THE LATEST AT THE TIME OF PRINTING AND SUBJECT TO CHANGE WITHOUT NOTICE.

NOTE: THE DC VOLTAGE AT EACH PART WAS MEASURED WITH THE DIGITAL TESTER WHEN THE COLOR BROADCAST WAS RECEIVED IN GOOD CONDITION AND PICTURE IS NORMAL.

PCBD24
CED019

TUNER/AV SCHEMATIC DIAGRAM

(AV PCB)

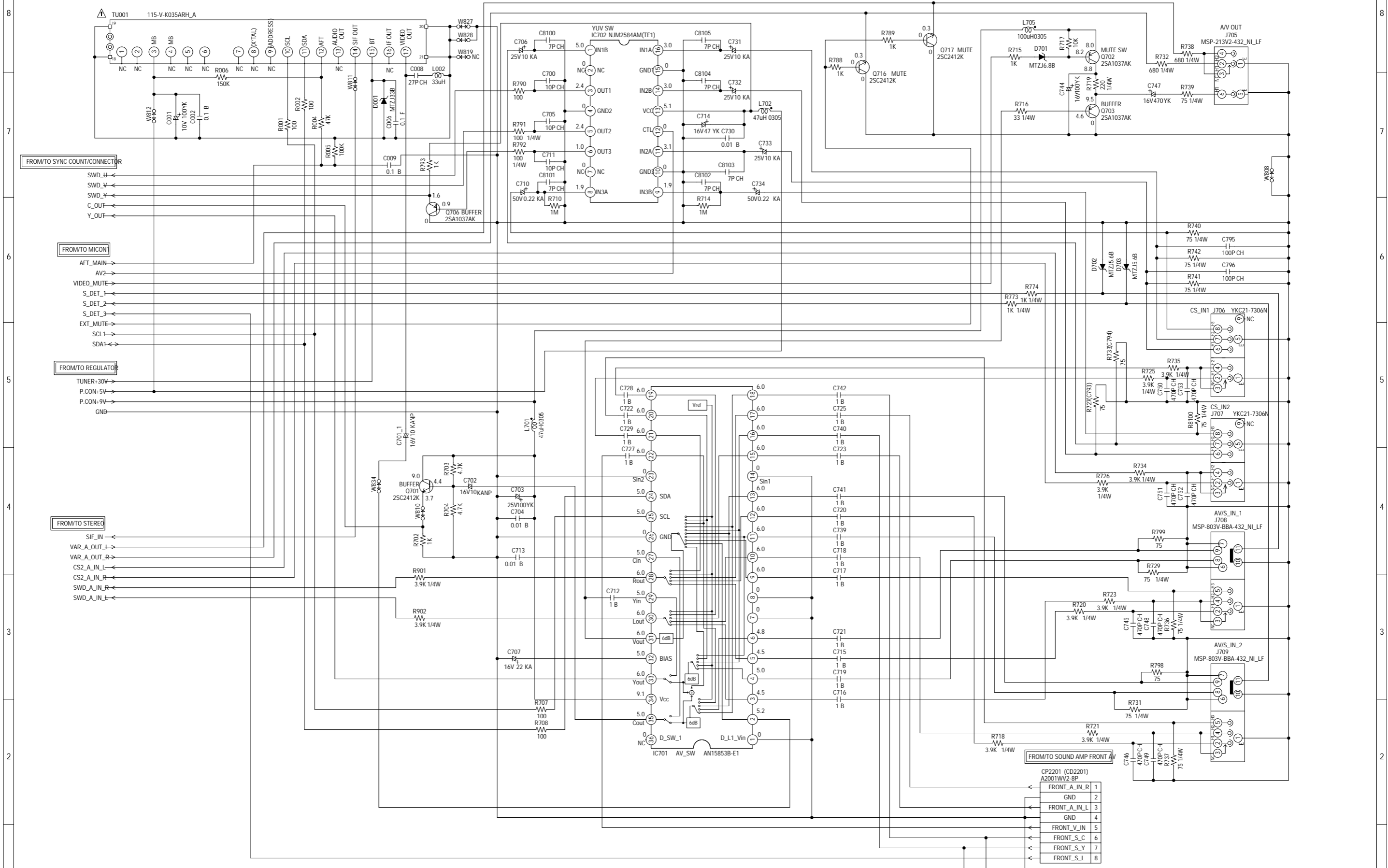

FROM/TO SYNC COUNT/CONNECTOR

- SWD_U
- SWD_V
- SWD_Y
- C_OUT
- Y_OUT

FROM/TO MICON

- AFT_MAIN
- AV2
- VIDEO_MUTE
- S_DET_1
- S_DET_2
- S_DET_3
- EXT_MUTE
- SCL1
- SDA1

FROM/TO REGULATOR

- TUNER+30V
- P.CON+5V
- P.CON+9V
- GND

FROM/TO STEREO

- SIF_IN
- VAR_A_OUT_L
- VAR_A_OUT_R
- CS2_A_IN_L
- CS2_A_IN_R
- SWD_A_IN_R
- SWD_A_IN_L

FROM/TO SOUND AMP FRONT

- | | |
|--------------|---|
| FRONT_A_IN_R | 1 |
| GND | 2 |
| FRONT_A_IN_L | 3 |
| GND | 4 |
| FRONT_V_IN | 5 |
| FRONT_S_C | 6 |
| FRONT_S_Y | 7 |
| FRONT_S_L | 8 |

NOTE: THIS SCHEMATIC DIAGRAM IS THE LATEST AT THE TIME OF PRINTING AND SUBJECT TO CHANGE WITHOUT NOTICE.

NOTE: THE DC VOLTAGE AT EACH PART WAS MEASURED WITH THE DIGITAL TESTER WHEN THE COLOR BROADCAST WAS RECEIVED IN GOOD CONDITION AND PICTURE IS NORMAL.

ATTENTION LES PIÈCES RÉPARÉES PAR UN ÉTANT DANGEREUSES AN POINT DE VUE SECURITE N'UTILISER QUE CELLS DECRITES DANS LA NOMENCLATURE DES PIÈCES.

CAUTION SINCE THESE PARTS MARKED BY ARE CRITICAL FOR SAFETY, USE ONES DESCRIBED IN PARTS LIST ONLY.

PCB20 CED019

REGULATOR SCHEMATIC DIAGRAM

(AV PCB)

FROM/TO OPERATION

12	GND
11	GND
10	AT+5V
9	AT+3.3V
8	UNREG+8V
7	UNREG+12V
6	UNREG+5V
5	TUNER+30V
4	POWER_FAIL
3	STANDBY_L
2	DEGAUSS_H
1	TV_POWER_H

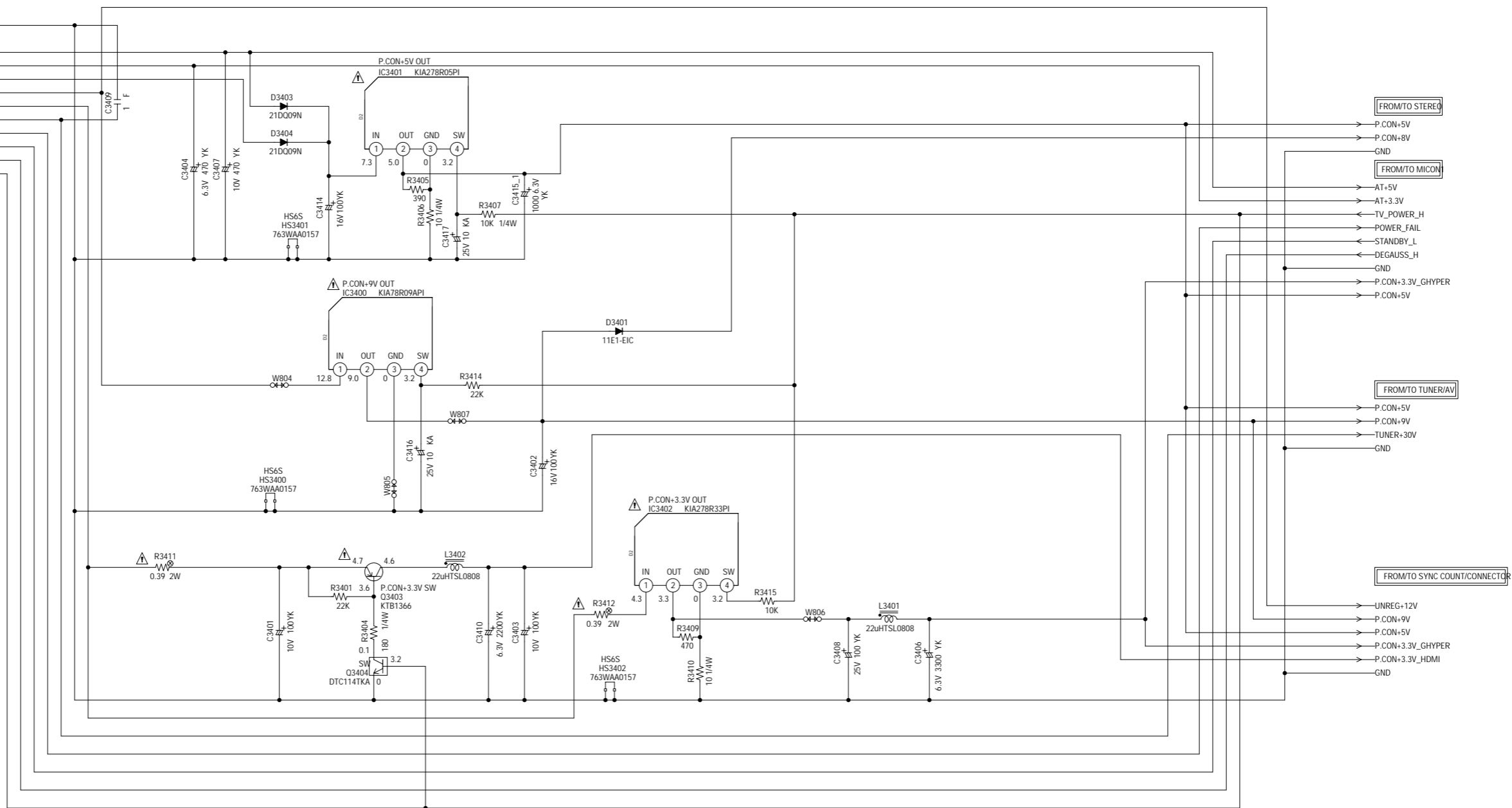

FROM/TO STEREO

P.CON+5V
P.CON+8V
GND
AT+5V
AT+3.3V
TV_POWER_H
POWER_FAIL
STANDBY_L
DEGAUSS_H
GND
P.CON+3.3V_GHYPER
P.CON+5V

FROM/TO TUNER/AV

P.CON+5V
P.CON+9V
TUNER+30V
GND

FROM/TO SYNC COUNT/CONNECTOR

UNREG+12V
P.CON+9V
P.CON+5V
P.CON+3.3V_GHYPER
P.CON+3.3V_HDMI
GND

NOTE: THIS SCHEMATIC DIAGRAM IS THE LATEST AT THE TIME OF PRINTING AND SUBJECT TO CHANGE WITHOUT NOTICE.

NOTE: THE DC VOLTAGE AT EACH PART WAS MEASURED WITH THE DIGITAL TESTER WHEN THE COLOR BROADCAST WAS RECEIVED IN GOOD CONDITION AND PICTURE IS NORMAL.

CAUTION SINCE THESE PARTS MARKED BY ARE CRITICAL FOR SAFETY, USE ONES DESCRIBED IN PARTS LIST ONLY.

ATTENTION LES PIÈCES RÉPARÉES PAR UN ÉTANT DANGEREUSES AN POINT DE VUE SÉCURITÉ, N'UTILISER QUE CELLES DÉCRITES DANS LA NOMENCLATURE DES PIÈCES.

CAUTION: DIGITAL TRANSISTOR

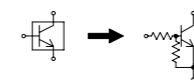

PCBD20
CED019

SYNC COUNT SCHEMATIC DIAGRAM

(AV PCB)

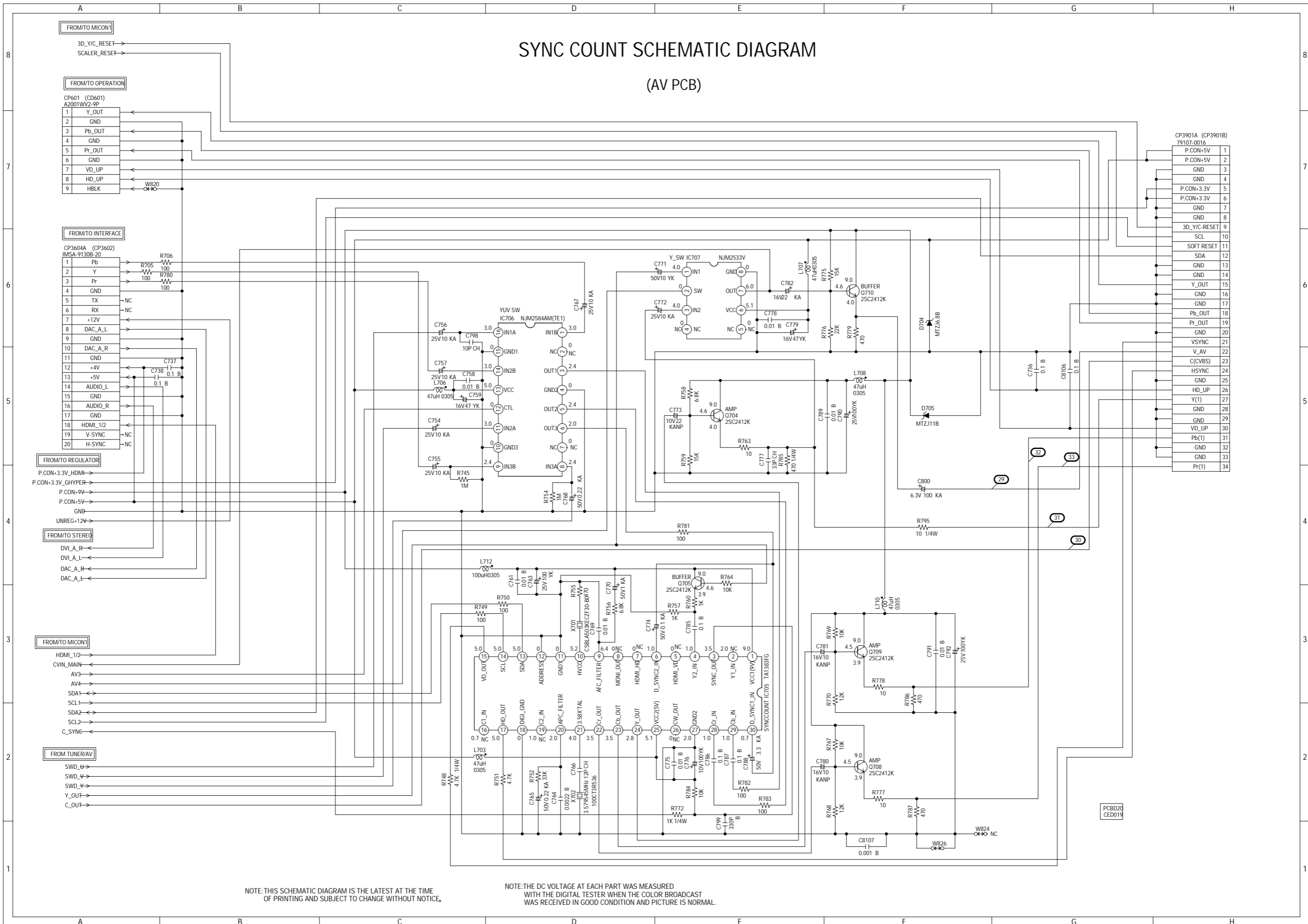

NOTE: THIS SCHEMATIC DIAGRAM IS THE LATEST AT THE TIME OF PRINTING AND SUBJECT TO CHANGE WITHOUT NOTICE.

NOTE: THE DC VOLTAGE AT EACH PART WAS MEASURED WITH THE DIGITAL TESTER WHEN THE COLOR BROADCAST WAS RECEIVED IN GOOD CONDITION AND PICTURE IS NORMAL.

CRT/SVM SCHEMATIC DIAGRAM (CRT PCB)

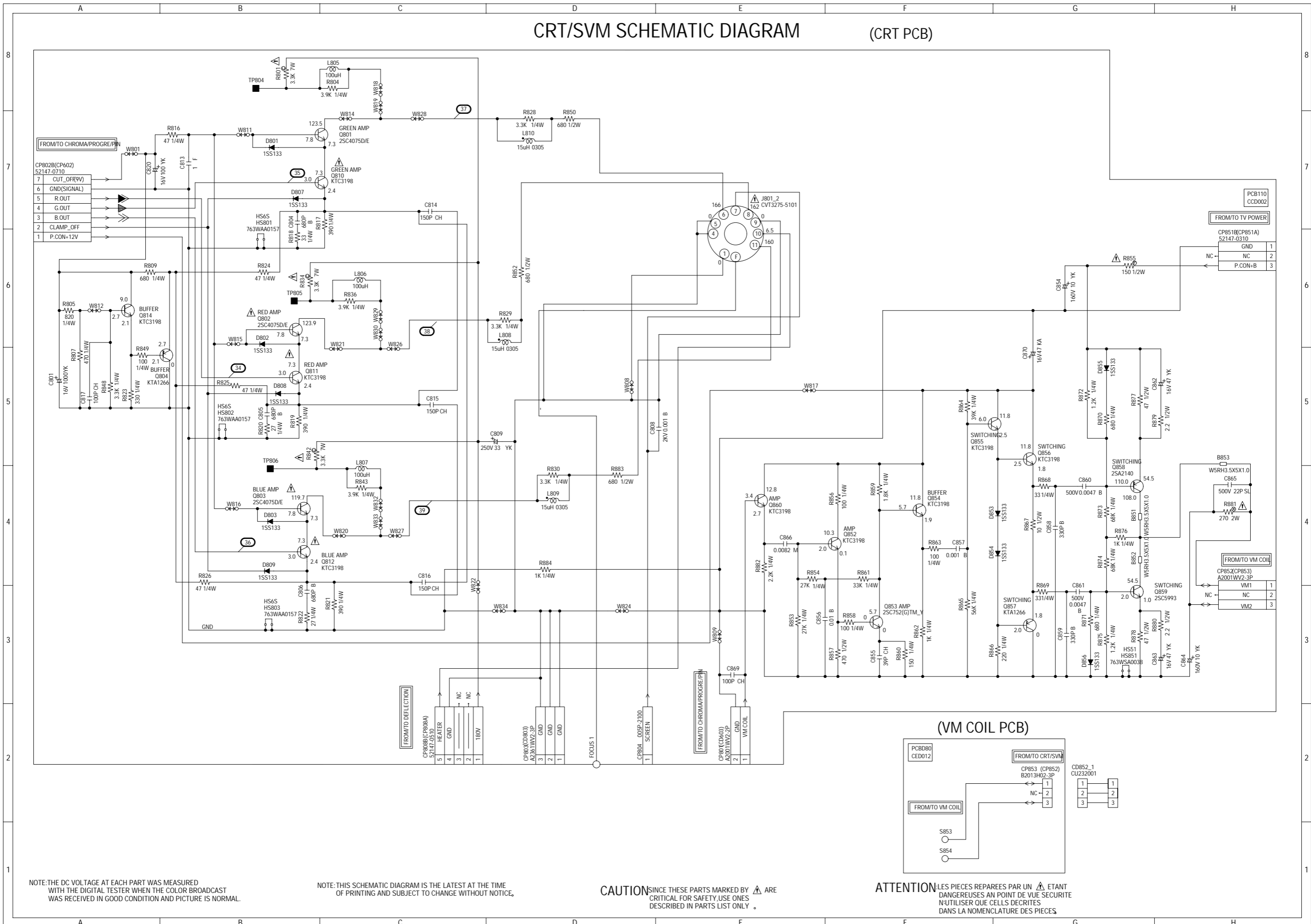

NOTE: THE DC VOLTAGE AT EACH PART WAS MEASURED WITH THE DIGITAL TESTER WHEN THE COLOR BROADCAST WAS RECEIVED IN GOOD CONDITION AND PICTURE IS NORMAL.

NOTE: THIS SCHEMATIC DIAGRAM IS THE LATEST AT THE TIME OF PRINTING AND SUBJECT TO CHANGE WITHOUT NOTICE.

CAUTION SINCE THESE PARTS MARKED BY ARE CRITICAL FOR SAFETY, USE ONES DESCRIBED IN PARTS LIST ONLY.

ATTENTION LES PIECES REPARÉES PAR UN ETANT DANGEREUSES AN POINT DE VUE SECURITE N'UTILISER QUE CELLES DECRITES DANS LA NOMENCLATURE DES PIECES.

INTERFACE SCHEMATIC DIAGRAM

(HD-MI PCB)

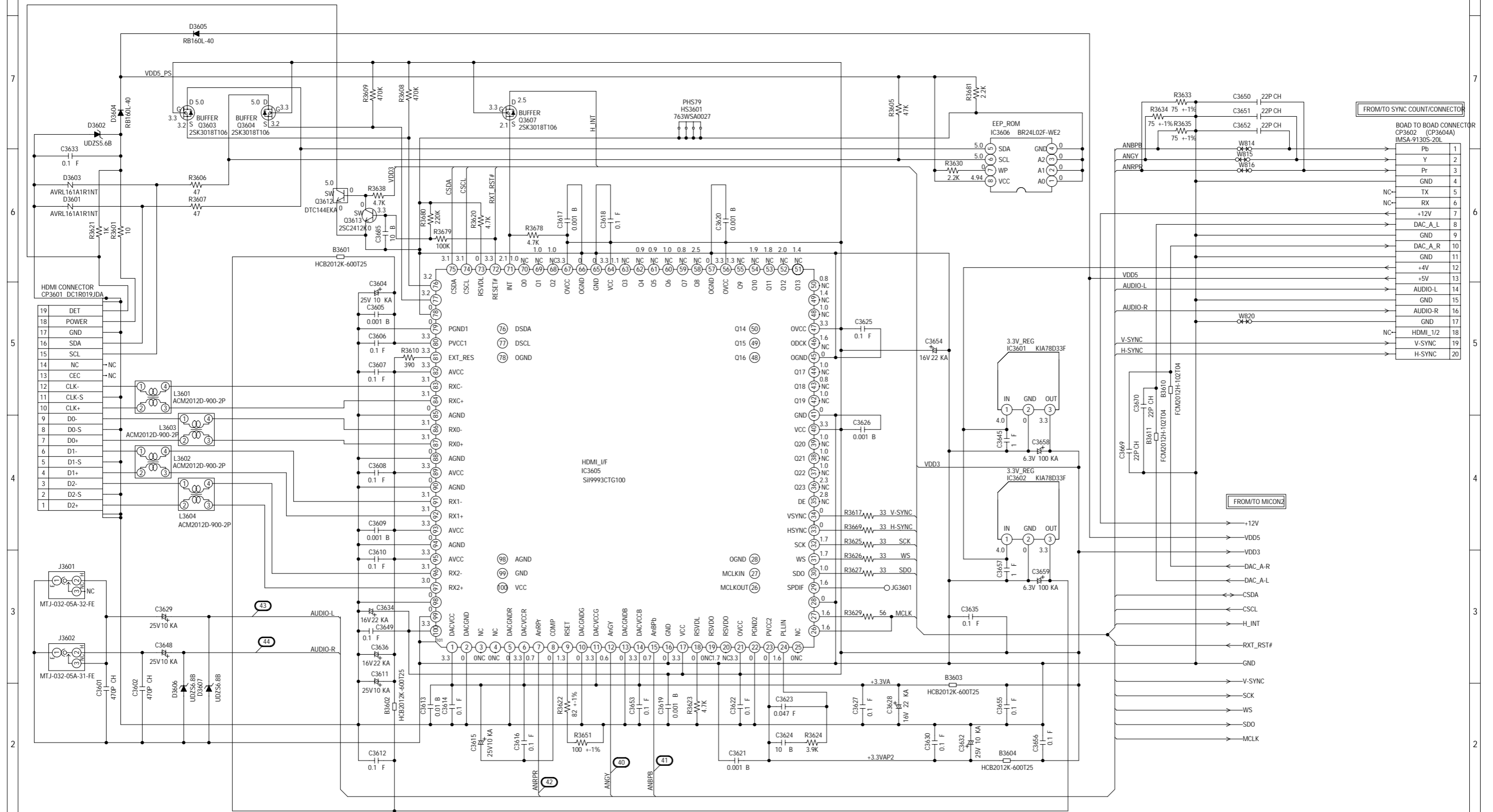

FROM/TO SYNC COUNT/CONNECTOR

BOARD TO BOARD CONNECTOR
CP3602 (CP3604A)
IMSA-9130S-20L

Pb	1
Y	2
Pr	3
GND	4
TX	5
RX	6
DAC_A_L	7
GND	8
DAC_A_R	9
GND	10
+12V	11
GND	12
+4V	13
+5V	14
AUDIO-L	15
GND	16
AUDIO-R	17
GND	18
HDMI_1/2	19
V-SYNC	20
H-SYNC	21

FROM/TO MICON2

CAUTION: DIGITAL TRANSISTOR

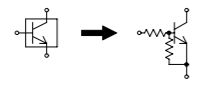

NOTE: THIS SCHEMATIC DIAGRAM IS THE LATEST AT THE TIME OF PRINTING AND SUBJECT TO CHANGE WITHOUT NOTICE.

NOTE: THE DC VOLTAGE AT EACH PART WAS MEASURED WITH THE DIGITAL TESTER WHEN THE COLOR BROADCAST WAS RECEIVED IN GOOD CONDITION AND PICTURE IS NORMAL.

PCBDJ0
CED011

MICON2 SCHEMATIC DIAGRAM

(HD-MI PCB)

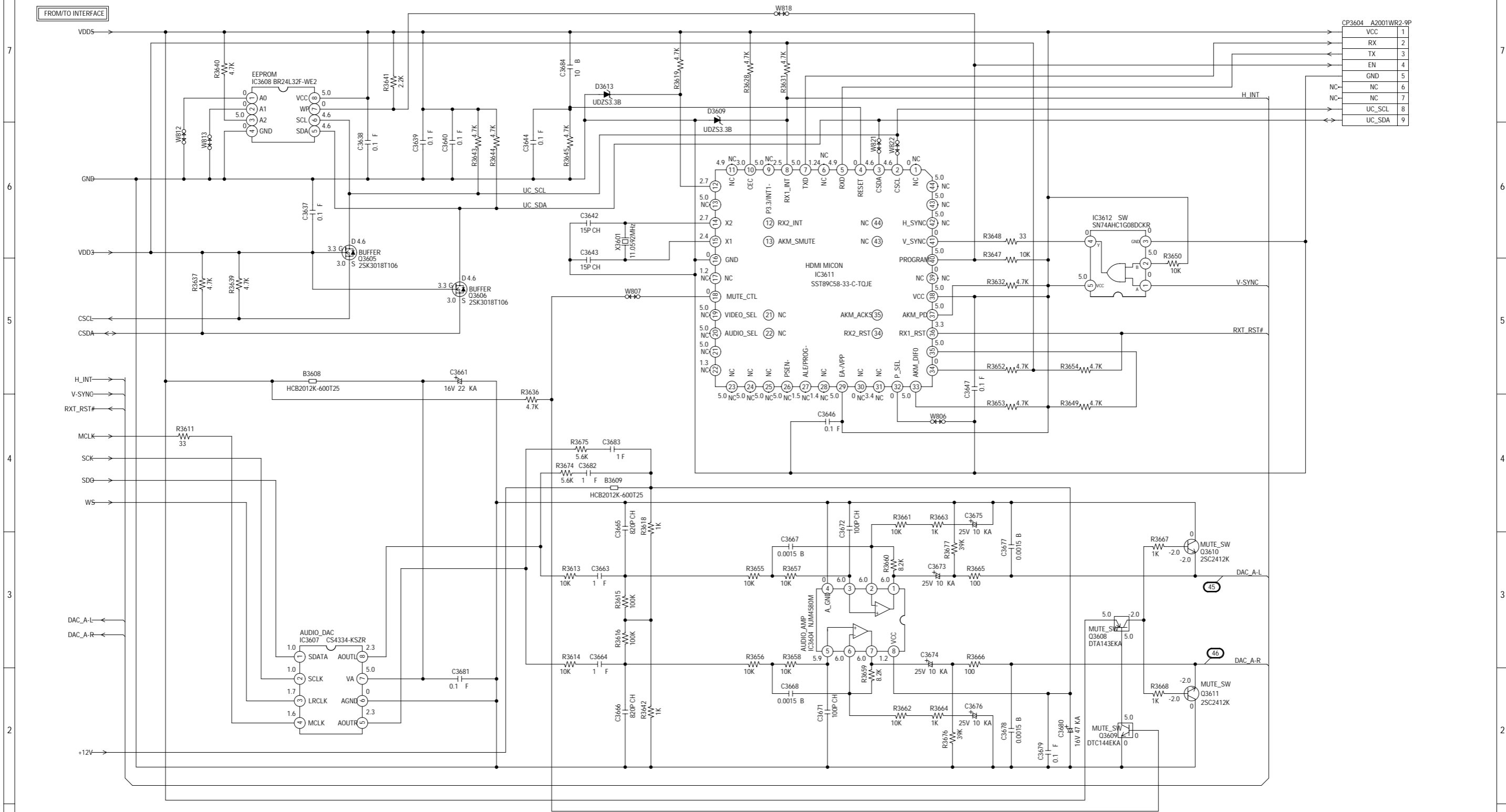

CP3604	A2001WR2-9P
VCC	1
RX	2
TX	3
EN	4
GND	5
NC	6
NC	7
UC_SCL	8
UC_SDA	9

CAUTION: DIGITAL TRANSISTOR

CAUTION: DIGITAL TRANSISTOR

NOTE: THIS SCHEMATIC DIAGRAM IS THE LATEST AT THE TIME OF PRINTING AND SUBJECT TO CHANGE WITHOUT NOTICE.

NOTE: THE DC VOLTAGE AT EACH PART WAS MEASURED WITH THE DIGITAL TESTER WHEN THE COLOR BROADCAST WAS RECEIVED IN GOOD CONDITION AND PICTURE IS NORMAL.

PCBDJ0
CED011

ANALOG/DIGITAL CONVERTER SCHEMATIC DIAGRAM

(SCALER PCB)

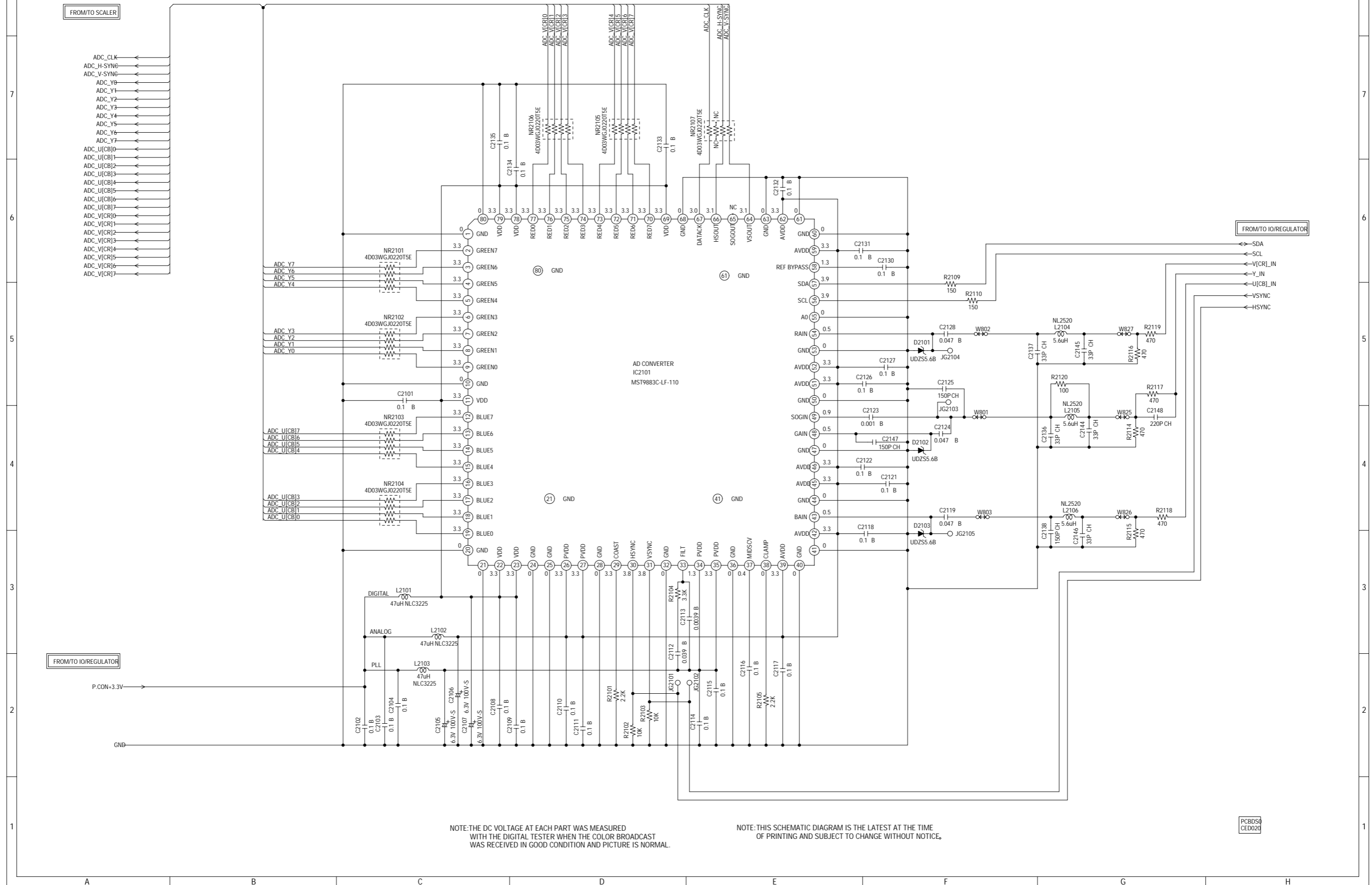

NOTE: THE DC VOLTAGE AT EACH PART WAS MEASURED WITH THE DIGITAL TESTER WHEN THE COLOR BROADCAST WAS RECEIVED IN GOOD CONDITION AND PICTURE IS NORMAL.

NOTE: THIS SCHEMATIC DIAGRAM IS THE LATEST AT THE TIME OF PRINTING AND SUBJECT TO CHANGE WITHOUT NOTICE.

PCBDSQ
CED020

SCALER SCHEMATIC DIAGRAM

(SCALER PCB)

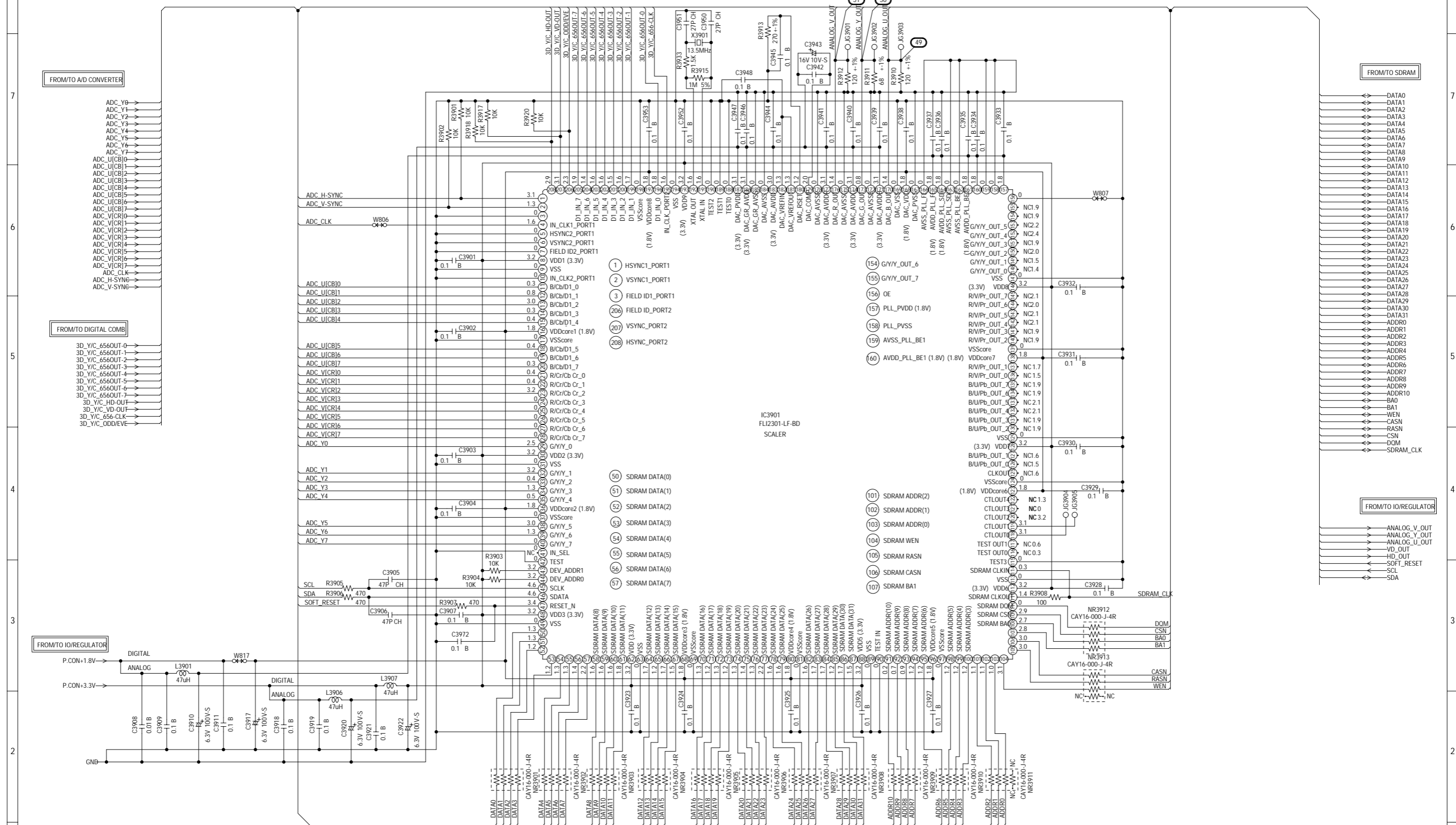

NOTE: THE DC VOLTAGE AT EACH PART WAS MEASURED WITH THE DIGITAL TESTER WHEN THE COLOR BROADCAST WAS RECEIVED IN GOOD CONDITION AND PICTURE IS NORMAL.

NOTE: THIS SCHEMATIC DIAGRAM IS THE LATEST AT THE TIME OF PRINTING AND SUBJECT TO CHANGE WITHOUT NOTICE.

PCBDS5 CED020

DIGITAL COMB SCHEMATIC DIAGRAM

(SCALER PCB)

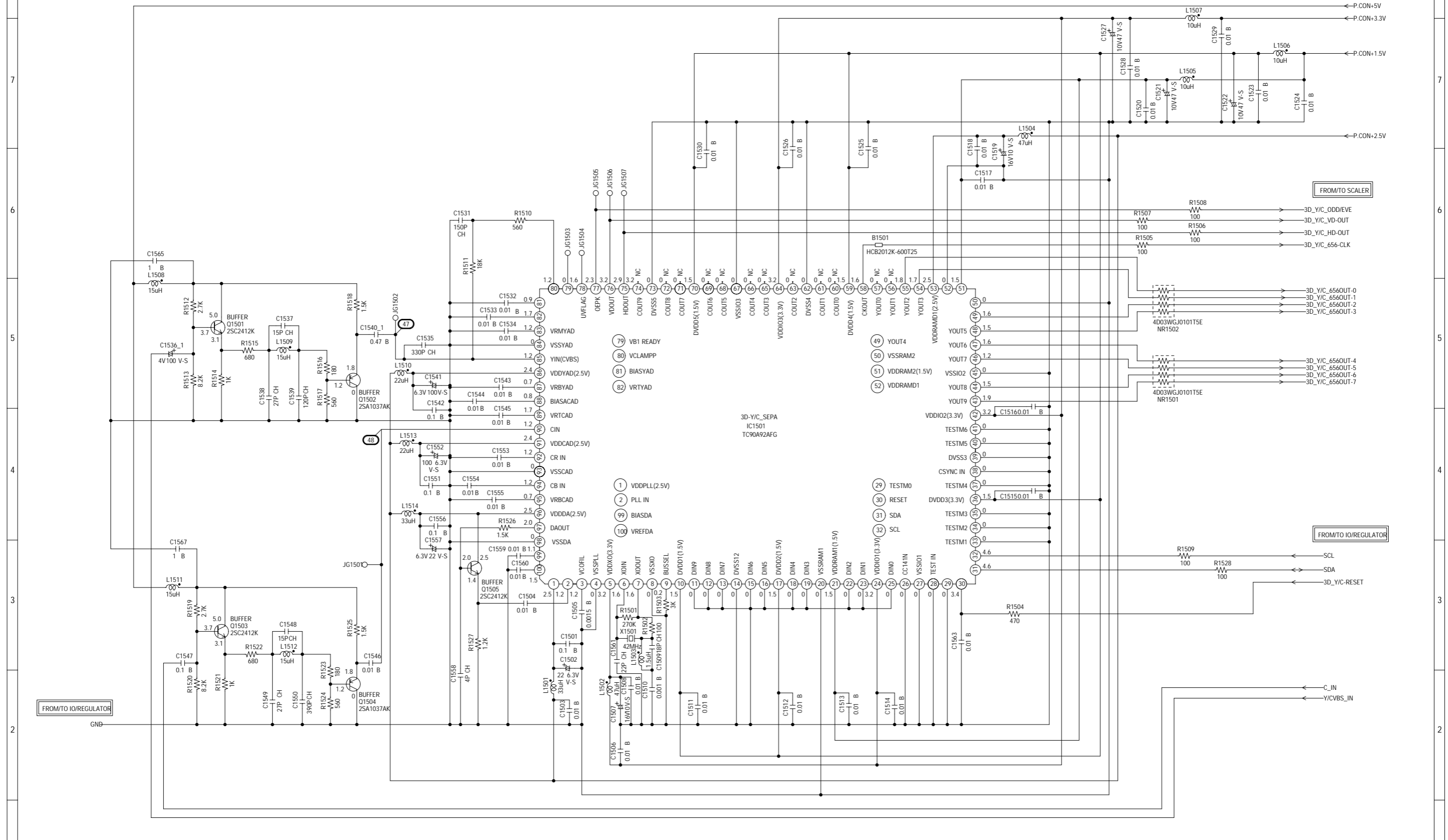

NOTE: THE DC VOLTAGE AT EACH PART WAS MEASURED WITH THE DIGITAL TESTER WHEN THE COLOR BROADCAST WAS RECEIVED IN GOOD CONDITION AND PICTURE IS NORMAL.

NOTE: THIS SCHEMATIC DIAGRAM IS THE LATEST AT THE TIME OF PRINTING AND SUBJECT TO CHANGE WITHOUT NOTICE.

PCBDS4
CED020

SDRAM SCHEMATIC DIAGRAM

(SCALER PCB)

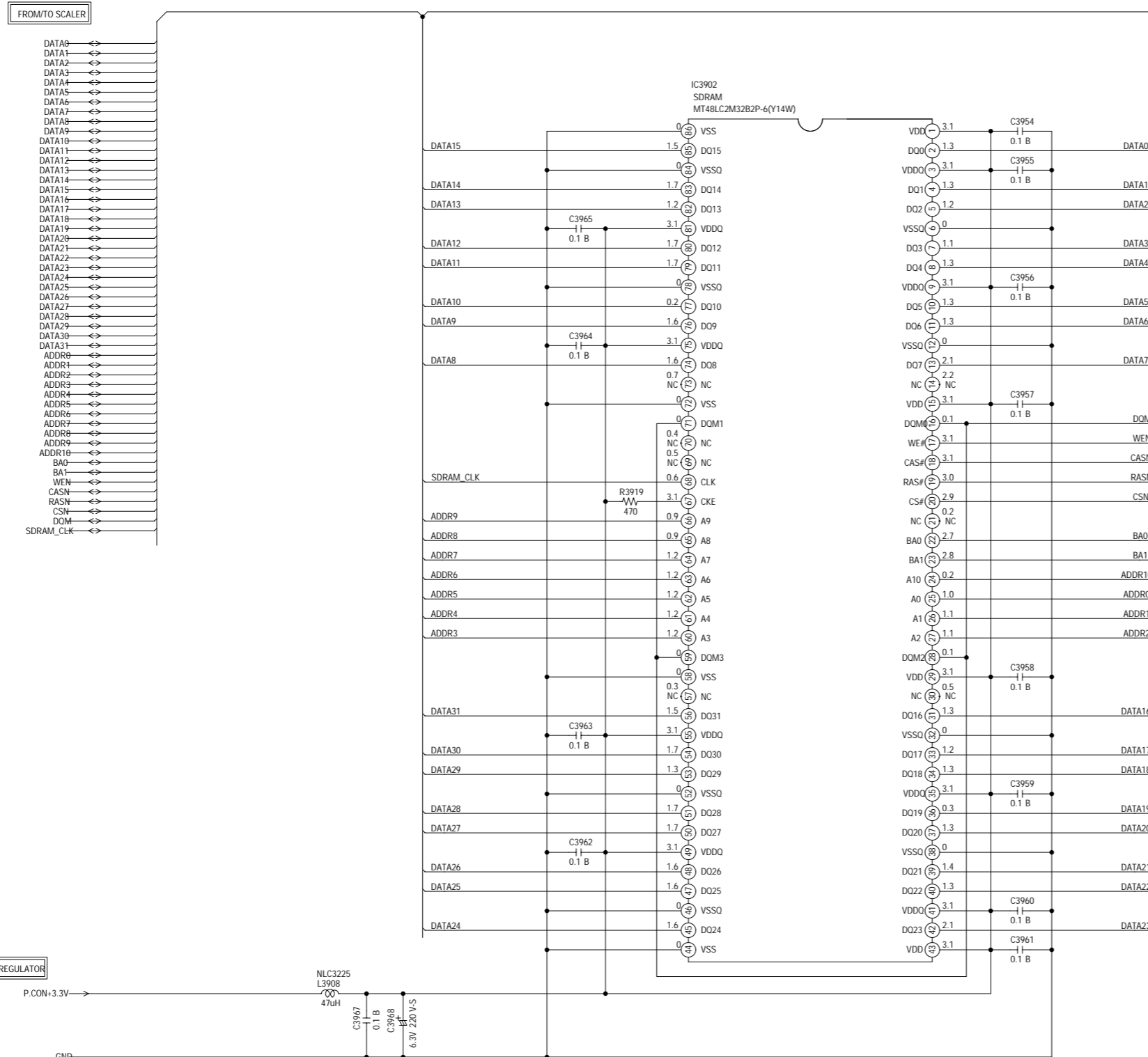

NOTE: THE DC VOLTAGE AT EACH PART WAS MEASURED WITH THE DIGITAL TESTER WHEN THE COLOR BROADCAST WAS RECEIVED IN GOOD CONDITION AND PICTURE IS NORMAL.

NOTE: THIS SCHEMATIC DIAGRAM IS THE LATEST AT THE TIME OF PRINTING AND SUBJECT TO CHANGE WITHOUT NOTICE.

PCBDS0
CED020

IO/REGULATOR SCHEMATIC DIAGRAM

(SCALER PCB)

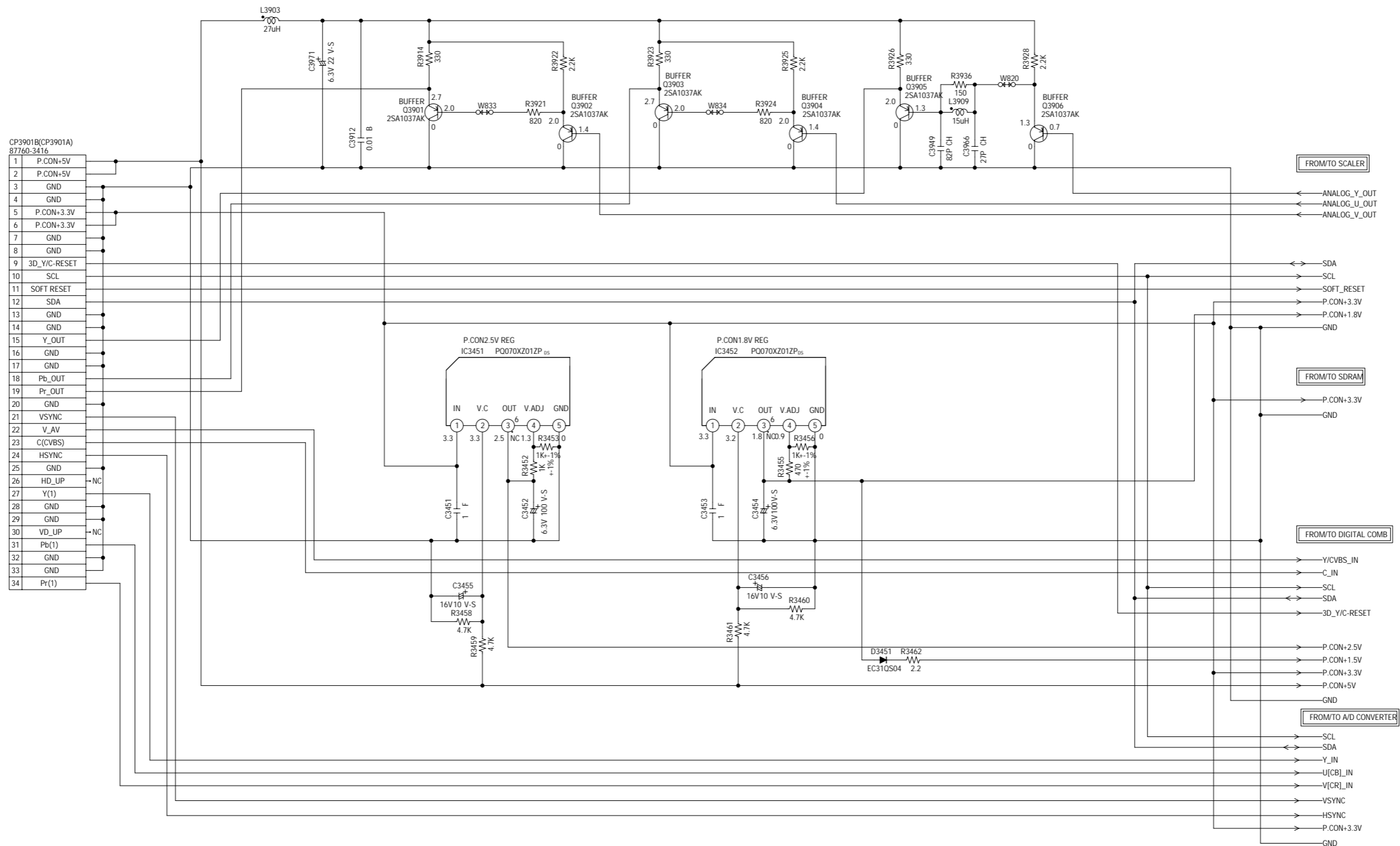

NOTE: THE DC VOLTAGE AT EACH PART WAS MEASURED WITH THE DIGITAL TESTER WHEN THE COLOR BROADCAST WAS RECEIVED IN GOOD CONDITION AND PICTURE IS NORMAL.

NOTE: THIS SCHEMATIC DIAGRAM IS THE LATEST AT THE TIME OF PRINTING AND SUBJECT TO CHANGE WITHOUT NOTICE.

PCB050
CED020

TOSHIBA CORPORATION

1-1, SHIBAURA 1-CHOME, MINATO-KU, TOKYO 105-8001, JAPAN